

## 174191.00 - SM-PLUS SERIES REMOTE KEYPAD INSTRUCTIONS

The SM-Plus Series Remote Keypad option allows the SM-Plus Series drive to be programmed and controlled from up to one hundred feet away. When properly mounted, the remote keypad is rated NEMA 4X.

In addition to the functions available on the front of the SM-Plus drive, the remote keypad has Start/Stop and Forward/Reverse functions.

**NOTE:** The Remote Keypad option will only work with SM-Plus drives that have parameter version "309" or "312". It will not work with SM-Plus drives that have the High Frequency or PI Setpoint Control options. The parameter version appears momentarily on the drive display when it is powered up, and also appears on a small label on the drive's heatsink.

### WARNING!

If OEM mode is selected (using Parameter 48), and if the OEM Default setting for Parameter 14 and/or 15 is "01", the remote keypad will be disabled, and the **STOP** key WILL NOT work. Refer to the SM-Plus Installation and Operation Manual for information on OEM Default settings.

## 1. PARTS LIST

The SM-Plus Remote Keypad kit includes the following parts:

- |                                  |                       |
|----------------------------------|-----------------------|
| (1) Remote Keypad                | (1) Gasket            |
| (2) Self-tapping Mounting Screws | (1) Instruction Sheet |
| (1) Eight foot cable             |                       |

**NOTE:** The supplied cable can only be used for distances up to 8 feet in low-noise environments. For distances up to 100 feet, or in high-noise environments, use Belden 9842, Carol C4842, or equivalent (24 gage minimum) wire only.

## 3. MOUNTING THE REMOTE KEYPAD

The diagram below illustrates how to mount the remote keypad to a panel. Use the template in Section 2 to mark the location of the mounting holes on the panel.

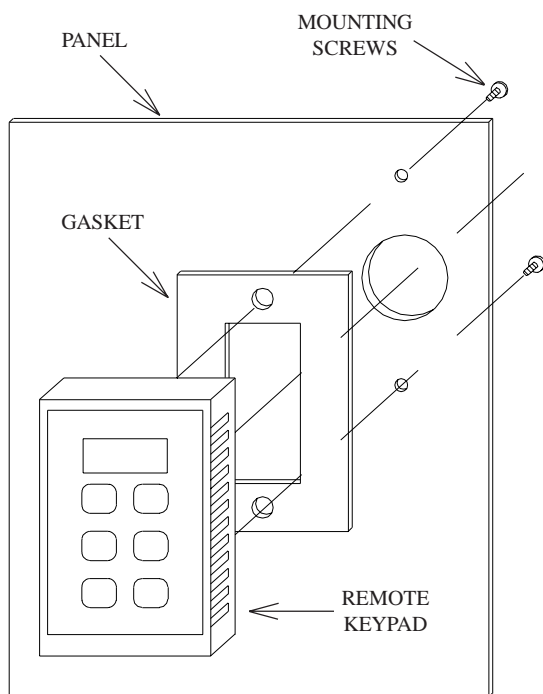

## 2. SM-PLUS REMOTE KEYPAD TEMPLATE

Hold this page against the panel where the remote keypad is to be mounted, and use a center punch to mark the location of the three holes. The dotted line is the outline of the remote keypad.

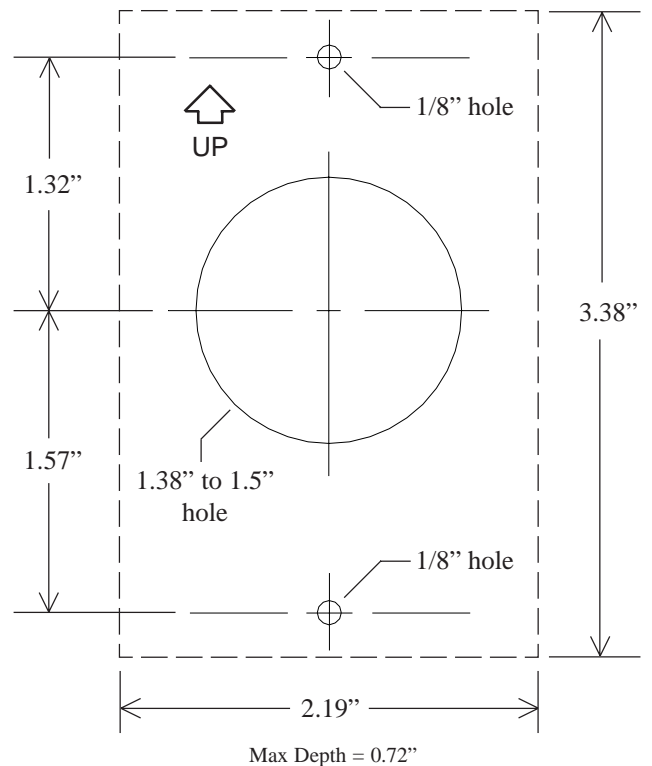

## 4. WIRING CONNECTIONS

### WARNING!

Improper wiring may result in damage to the Remote Keypad. Keep the remote keypad cable away from power wiring.

The Belden and Carol cables specified consist of two twisted pairs. Make sure one twisted pair is used for power and the other is used for serial communications. Do not mix connections between twisted pairs.

**NOTE 1:** The supplied cable can be used for distances up to 8 feet in low-noise environments. For distances up to 100 feet, or in high-noise environments, use Belden 9842, Carol C4842, or equivalent (24 gage minimum) wire only.

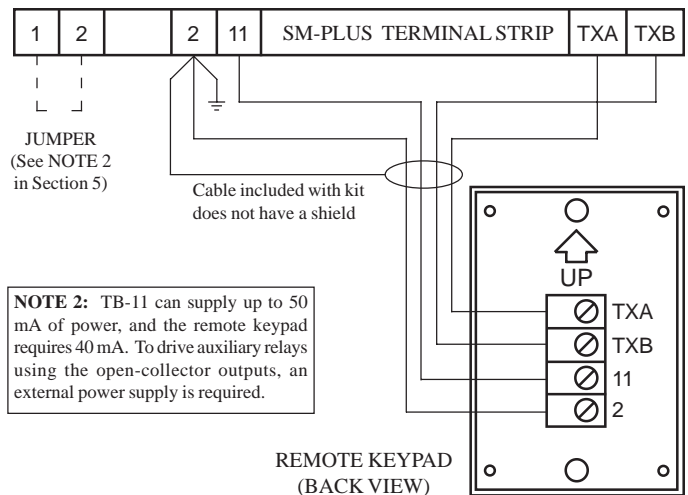

## 5. SETTING UP THE SM-PLUS DRIVE

There are three possible control scenarios when using the remote keypad:

1. The remote keypad is used for Start/Stop control, Forward/Reverse selection, programming, and monitoring.
2. The remote keypad is used for programming and monitoring, but the drive's terminal strip is used for Start/Stop control and Forward/Reverse selection.
3. The remote keypad is used for programming and monitoring, while Start/Stop control and Forward/Reverse selection can be toggled between the remote keypad and the drive's terminal strip.

In all of the above scenarios, speed is controlled from the remote keypad unless another speed reference source is selected.

**NOTE 1:** The **STOP** key on the remote keypad will work even if the terminal strip is used for Start/Stop control.

### 1. REMOTE KEYPAD TO PROGRAM, MONITOR AND CONTROL

- a. Set Parameter 14 (CONTROL) to "02" (REMOTE KEYPAD ONLY).
- b. Install a jumper between terminal TB-1 and TB-2 on the drive's terminal strip.

### 2. REMOTE KEYPAD TO PROGRAM AND MONITOR, AND TERMINAL STRIP TO CONTROL.

- a. Set Parameter 14 (CONTROL) to "03" (TERMINAL STRIP OR REMOTE KEYPAD).
- b. Wire the Start/Stop and Forward/Reverse circuits to the drive's terminal strip according to the SM-Plus manual.

### 3. TOGGLE CONTROL BETWEEN REMOTE KEYPAD AND TERMINAL STRIP

- a. Set Parameter 14 (CONTROL) to "03" (TERMINAL STRIP OR REMOTE KEYPAD).

- b. Choose either Terminal 13A or 13C on the drive as the input that will toggle between remote keypad control and terminal strip control.

To use TB-13A, set Parameter 10 (TB-13A FUNCTION SELECT) to "08" (REMOTE KEYPAD).

To use TB-13C, set Parameter 12 (TB-13C FUNCTION SELECT) to "07" (REMOTE KEYPAD).

- c. Wire a selector switch or relay contact between TB-13A or TB-13C (whichever was programmed for REMOTE KEYPAD in Step b above) and TB-2 on the drive's terminal strip.

- d. Wire the Start/Stop and Forward/Reverse circuits to the drive's terminal strip according to the SM-Plus manual.

**NOTE:** If a 2-wire Start/Stop circuit is required, use the Alternate 2-Wire circuit described in Section 11.3 of the SM-Plus manual.

To select the Remote Keypad as the control source, close TB-13A or TB-13C (whichever was programmed for REMOTE KEYPAD) to TB-2.

To select the terminal strip as the control source, open TB-13A or TB-13C with respect to TB-2.

**NOTE 2:** When the remote keypad is selected for Start/Stop control, terminal TB-1 on the SM-Plus drive must be closed to TB-2 to allow the drive to run. TB-1 is a Stop input and it is always active. If it is open with respect to TB-2, the drive will not run.

## 6. REMOTE KEYPAD FUNCTIONS

The **M** key and the **▲** and **▼** keys on the remote keypad function the same as the **Mode** button and the **▲** and **▼** buttons on the drive. The other remote keypad functions are described below:



**Reverse/Forward** key: Selects Forward or Reverse direction. The **R/F** key is only active if Parameter 17 - ROTATION is set to "2" (FORWARD AND REVERSE).

When the **R/F** key is pressed, the symbol for the opposite direction will blink on the display. Press the **M** key within four seconds to confirm the rotation change.

Below are the display symbols used to indicate direction:



FORWARD



REVERSE



**RUN** key: Press **RUN** to Start the drive. The **RUN** key is only active if the remote keypad is selected as the Start/Stop control source.



**STOP** key: Press **STOP** to Stop the drive. The **STOP** key is active whenever the remote keypad is operational, even if the remote keypad is only used for programming and monitoring.

## 7. TROUBLESHOOTING

CONDITION / DISPLAY	POSSIBLE CAUSES
Remote Keypad display is blank.	Parameter 14 - CONTROL is set to "01" (TERMINAL STRIP ONLY) The Remote Keypad is not wired correctly to the drive.
Remote Keypad and/or SM-Plus drive displays "JF"	JF is a serial fault, which indicates a communication problem. Check for proper wiring between the remote keypad and the drive. A "JF" fault will also occur if an attempt is made to power the remote keypad and an auxiliary relay from TB-11. See Note 2 in Section 4.
The RUN key does not work to start the drive.	To start the drive using the RUN key, the Remote Keypad must be selected as the control source, and TB-1 must be closed to TB-2 on the drive's terminal strip. Refer to Sections 4 and 5, relay from TB-11. See Note 2 in Section 4.
The R/F key does not work to change rotation direction.	To use the R/F key to change rotation direction, the remote keypad must be selected as the control source, and Parameter 17 (ROTATION) must be set to "02" (FORWARD AND REVERSE). Refer to Sections 4 and 5.

### WARNING!

If the remote keypad display is totally blank or is displaying a "JF" fault, the **STOP** key WILL NOT stop the drive. The remote keypad must be operational in order for the **STOP** key to be active.

