

**⚠ WARNING** indicates a hazard which, if not avoided, could result in serious injury or death.

**⚠ CAUTION** indicates a hazard which, if not avoided, could result in minor or moderate personal injury.

### BEARING MOUNTING PROCEDURE

**WARNING!** These instructions should be read entirely and followed carefully before attempting to install or remove Link-Belt split housed roller bearings. Failure to do so can result in improper installation which could cause bearing performance problems as well as serious personal injury.

### SERIES 6600, 6800, 6900

#### ADAPTER MOUNTED UNITS (6600, 6800, & 6900)

1. Inspect shaft size (See Shaft Tolerance **Table 3**). Shaft must be to correct size. Clean shaft and mounting surface as needed.
2. Position housing base onto mounting surface. Snug down mounting bolts.
3. Slide on seal, adapter assembly, bearing, and second seal onto the shaft in the correct order. If “B” felt seals are used, hold until step 8.

**TABLE 1 — Clearance Reduction  
(All values in inches) C3 Bearing**

Pillow Block Range		Radial Unmounted Clearance (in)		Final Operating Clearance (in)		Clearance Reduction (in)	
From	To	Min	Max	Min	Max	Min	Max
6823	6828	.0024	.0031	.0012	.0021	.0010	.0012
6831	6835	.0030	.0037	.0014	.0025	.0012	.0016
6839	6843	.0037	.0047	.0017	.0031	.0016	.0020
6847	6856	.0043	.0055	.0019	.0037	.0018	.0024
6859	6867	.0053	.0067	.0025	.0047	.0020	.0028
6871	6880	.0063	.0079	.0028	.0053	.0026	.0035
6883	6887	.0071	.0091	.0032	.0061	.0030	.0039
6895	68104	.0079	.0102	.0036	.0071	.0031	.0043
68111	68115	.0087	.0114	.0036	.0079	.0035	.0051
68120	68128	.0098	.0126	.0043	.0087	.0039	.0055
66135	66144	.0106	.0138	.0047	.0095	.0043	.0059
66151	68168	.0118	.0154	.0051	.0107	.0047	.0067
66175	66176	.0130	.0169	.0055	.0118	.0051	.0075
6923	6927	.0024	.0031	.0012	.0021	.0010	.0012
6931	6935	.0030	.0037	.0014	.0025	.0012	.0016
6936	6943	.0037	.0047	.0017	.0031	.0016	.0020
6947	SAF307	.0043	.0055	.0019	.0037	.0018	.0024
315	403	.0053	.0067	.0025	.0047	.0020	.0028
407	500	.0063	.0079	.0028	.0053	.0026	.0035
503	507	.0071	.0091	.0032	.0061	.0030	.0039
SAF22634	515	.0079	.0102	.0036	.0071	.0031	.0043

4. Locate the bearing and sleeve snugly on the shaft in the desired position. Fixed bearings are located with the bearing face opposite the locknut up against the housing shoulder. Expansion bearings are usually centered in the housing seat between the shoulders to allow for shaft expansion or contraction. A shaft with a pair of bearings normally has one fixed and one expansion pillow block. The fixed unit is usually located adjacent to the drive. The fixed bearing takes any thrust loads. In locating, take into account that tightening correctly will move the bearing further up the tapered sleeve. Do not tighten locknut beyond finger tight at this time.
5. Measure the initial built in clearance across the top of both sets of rollers as shown in **Figure 1**. It must be possible to remove shim by pulling straight out.
6. Using a spanner wrench, tighten the locknut until snug (**Figure 2**). Hold the adapter sleeve from turning until firmly seated. Using a soft steel bar and a hammer, drive against the face of the locknut as shown to relieve the thread pressure (**Figure 3**). Retighten the locknut and repeat until the correct adjustment specified in Clearance Reduction **Table 1** is achieved.
7. Bend a tang of lockwasher into slot of locknut. If tang does not line up, tight locknut until closest tang lines up.

**Figure 1 — Measuring Initial Clearance**

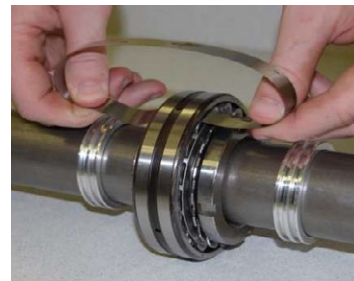

**Figure 2 — Tighten Until Snug**



**Figure 3 — With a soft steel bar tap on face of locknut**



**Figure 4 — Checking Alignment**

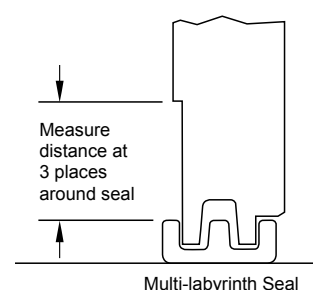

8. If felt seal halves are not fastened to the cap with adhesive this should be done. Dry the seal grooves in both sides of the cap to remove oil and preservative. Apply a good quality rubber cement evenly to both the seal O.D. and the housing seal bore. Do not get adhesive on the felt. When adhesive dries to slight tackiness, install the seal halves in the cap. Install the other halves in the base before the shaft is in place, then wet the felts with oil. The shaft holds seals in place for complete drying. Do not operate until adhesive is set.
9. Force grease in one side of the bearing until it comes out the other side all the way around. Fill grease reservoir on both sides to the bottom of the shaft. See Lubrication Information on **Page 3** for more information.
10. Install spacer ring between the bearing and housing shoulder to fix the unit in place. Skip this step if expansion unit is required.
11. For oil lubricated bearings, apply non-hardening gasket compound to cap surfaces which contact the base (Not needed for grease lubrication). Tighten cap nuts or bolts securely. Bolts should be fully tightened with a torque wrench to values in **Table 2**. Where bearings are to be periodically removed, use 75% of these values. Use oil only on the bolt threads.
12. With the mounting bolts snug, check the alignment and freedom of rotation. **“B” seals:** Visually check the clearance between the shaft and the bore of the seal. This clearance is small and can be visually checked for uniformity all the way around the seal. **“R” or “H” seals:** Measure the distance between the outside diameter of the seal and the diameter of the housing counterbore in three places. Be sure that each measurement is taken 90 degrees from the previous measurement. All three measurements should be uniform to insure proper alignment. See **Figure 4**. Align by shimming or shifting as necessary. Use large area shims to avoid distorting the housing and pinching the bearing. Appropriate use of stop bars against faces or ends of feet opposite the direction of load or vibration to avoid shifting of the housing is recommended. Dowel pins can be equally effective if properly used. This is especially important where loads are not directly down through the base. Finally, tighten or torque mounting bolts securely. Up to SAE Grade 5 mounting bolts can be used, properly torqued, to mount cast iron housings (See **Table 2A**). Up to SAE Grade 8 mounting bolts can be used, properly torqued, to mount cast steel housings (see **Table 2B**).

### ADDITIONAL INSTALLATION COMMENTS

1. Cap and base are machined as matched unit and are not interchangeable. The machined split line on base is marked and should be matched to corresponding cap.
2. If outer rings become misaligned, do not force back into position. Instead, carefully work back by turning and sliding.
3. **For installation of D5 see page 5. For installation of D8 Sealing arrangements see page 6.**

**Table 2A — Recommended Housing Cap Bolt Tightening Torque**

CAST IRON HOUSING			
Series 6800/6600	Tightening Torque (lb-ft / N-m)	Series 6900/SAF22600	Tightening Torque (lb-ft / N-m)
6823-6840	45-50 / 61-68	6923-6932	45-50 / 61-68
6841-6852	90-100 / 122-136	6933-6944	90-100 / 122-136
6853-6868	160-180 / 217-245	6945-6948	160-180 / 217-245
6869-6872	280-330 / 280-448	22618	90-100 / 122-136
6873-68104	400-430 / 542-583	22620-22622	160-180 / 217-245
68105-68115	630-700 / 854-950	22624-22626	160-180 / 217-245
68117-68128	800-890 / 1085-1207	22628-22630	220-250 / 298-339
66129-66144	630-700 / 854-950	22632	320-350 / 434-475
66145-66168	800-890 / 1085-1207	22634	450-500 / 610-678
66169-66176	1400-1500 / 1900-2034	...	...

**TABLE 2B — Recommended Housing Cap Bolt Tightening Torque**

CAST STEEL HOUSING			
Series 6800	Series 6600	Tightening Torque (lb-ft / N-m)	
		Load Directed into Base	Load Directed into Cap
6839-6840	...	50-65 / 68-88	80-110 / 109-149
6841-6848	...	100-130 / 135-176	160-220 / 217-298
6853-6864	...	170-230 / 230-312	300-400 / 407-543
6869-6872	...	280-370 / 380-502	490-650 / 665-882
6873-6880	...	410-550 / 556-746	730-970 / 990-1315
6883-68104	...	580-780 / 787-1058	1030-1370 / 1397-1858
68105-68116	66129-66144	820-1100 / 1112-1492	1450-1940 / 1966-2630
68117-68128	66B151-66168	1430-1900 / 1940-2576	2530-3370 / 3430-4570
...	66169-66176	1400-1550 / 1900-2102	2530-3370 / 3430-4570

**TABLE 3 — Recommended Shaft Tolerance**

SHAFT TOLERANCE TABLE (INCHES)				
Nominal Shaft Sizes (inches)		Commercial Shaft Tolerance* (Cold Finished Steel, Low Carbon)	RECOMMENDED SHAFT TOLERANCES*	
Over	Incl.		Adapter Mounting	Press Fit Mounting
1 7/16	2	+ .000 - .003"	+ .000 - .003"	Consult Regal Rexnord™
2 1/16	4	+ .000 - .004"	+ .000 - .004"	
4 1/16	6	+ .000 - .005"	+ .000 - .005"	
6 1/16	13	+ .000 - .006"	+ .000 - .006"	

\* Recommended shaft tolerances are generally satisfactory for loads up to 15% of C (see load ratings in catalog). High load applications will require a press fit to the shaft.



**GREASE LUBRICATION** is recommended wherever conditions in Table 4 exist. For conditions which are not completely covered in Table 4 consult Regal Rexnord™ Bearing Division. A reputable lubricant manufacturer should be consulted to confirm the lubricant selection and application.

**Relubrication After Running** — Relubrication of units in service should be through the fitting or hole in the center of the unit when bearings with lube holes and grooves are used as normally supplied. The amount of grease used should be enough to purge old grease from the bearing only (not the entire pillow block) and form a cushion of grease adjacent to the bearing face.

**High Speed Operation** – Consult **Table 4** for a guide to correct greases and frequency of relubrication. High speed bearings will not operate satisfactory when packed full of grease. As relubrication will eventually fill the housing cavities, it may be necessary to remove the cap periodically, clean out the old lubricant and repack with the original amount.

- Operating temperature limited to -40 to +225°F
- “Dirty,” Corrosive or Wet environments require more frequent re-lube
- D8 seal limit is 1500 surface feet per minute
- B felt seal limit is 800 surface feet per minute
- Reduce lubrication intervals by half for vertical shaft applications

**TABLE 4 — Grease Lubrication Information**

LUBRICATION TABLE (HORIZONTAL SHAFT APPLICATION)					
6800/6600 Series Shaft Size (Inches)	To Relubricate Units	RECOMMENDED NUMBER OF MONTHS BETWEEN RELUBRICATION* (BASED ON 24/7 OPERATION)			
		Relube Interval			
		6 Months	4 Months	2 Months	1 Month
<b>1 7/16 – 1 1/2</b>	0.15 oz.	2400	3600	5000	5500
<b>1 11/16 – 1 3/4</b>	0.15 oz.	2200	3300	4500	5000
<b>1 15/16 – 2</b>	0.20 oz.	2200	3000	4000	4500
<b>2 3/16 – 2 1/4</b>	0.40 oz.	1700	2500	3400	3800
<b>2 7/16 – 2 1/2</b>	0.40 oz.	1450	2200	3000	3400
<b>2 11/16 – 2 3/4</b>	0.45 oz.	1350	2000	2800	3300
<b>2 15/16 – 3</b>	0.60 oz.	1300	1900	2600	3000
<b>3 3/16 – 3 1/4</b>	0.85 oz.	1200	1800	2400	2700
<b>3 7/16 – 3 1/2</b>	1.15 oz.	1100	1650	2200	2300
<b>3 11/16 – 4</b>	1.60 oz.	1000	1500	1950	2100
<b>4 3/16 – 4 1/4</b>	2.15 oz.	900	1350	1850	1900
<b>4 7/16 – 4 1/2</b>	2.80 oz.	840	1250	1700	1800
<b>4 15/16 – 5</b>	3.20 oz.	780	1150	1600	1700
<b>5 3/16 – 5 1/4</b>	4.00 oz.	730	1100	1500	1600
<b>5 7/16 – 5 1/2</b>	5.10 oz.	680	1000	1400	1500
<b>5 15/16 – 6</b>	6.10 oz.	640	970	1300	1400
<b>6 7/16 – 6 1/2</b>	6.40 oz.	610	910	1200	1300
<b>6 15/16 – 7</b>	7.70 oz.	570	860	1100	1200
<b>7 3/16 – 7 1/4</b>	11.70 oz.	550	820	1000	1100
<b>7 1/2 – 8</b>	13.40 oz.	500	750	900	1000
		Shaft Speed in RPM			
<b>Clean and Repack Interval</b>		5 Years	3 Years	2 Years	1 Year

LUBRICATION TABLE (HORIZONTAL SHAFT APPLICATION)					
6900/SAF22600 Shaft Size (Inches)	To Relubricate Units	RECOMMENDED NUMBER OF MONTHS BETWEEN RELUBRICATION* (BASED ON 24/7 OPERATION)			
		Relube Interval			
		6 Months	4 Months	2 Months	1 Month
<b>1 7/16 – 1 1/2</b>	0.35 oz.	1325	2100	3150	4200
<b>1 11/16 – 1 3/4</b>	0.55 oz.	1200	1900	2850	3800
<b>1 15/16 – 2</b>	0.65 oz.	1075	1800	2700	3600
<b>2 3/16 – 2 1/4</b>	0.95 oz.	925	1500	2250	3000
<b>2 7/16 – 2 1/2</b>	1.30 oz.	800	1300	1950	2600
<b>2 11/16 – 2 3/4</b>	1.60 oz.	750	1250	1875	2500
<b>2 15/16 – 3</b>	1.80 oz.	700	1150	1725	2300
<b>3 3/16 – 3 1/4</b>	2.15 oz.	650	1100	1650	2200
<b>3 7/16 – 3 1/2</b>	3.10 oz.	600	1000	1500	2000
<b>3 11/16 – 4</b>	4.15 oz.	550	900	1350	1800
<b>4 3/16 – 4 1/4</b>	5.80 oz.	500	800	1200	1600
<b>4 7/16 – 4 1/2</b>	6.70 oz.	450	750	1125	1500
<b>4 15/16 – 5</b>	8.45 oz.	425	700	1050	1400
<b>5 3/16 – 5 1/4</b>	11.00 oz.	400	650	975	1300
<b>5 7/16 – 5 1/2</b>	13.00 oz.	375	625	950	1250
<b>5 15/16 – 6</b>	15.50 oz.	350	575	850	1150
		Shaft Speed in RPM			
<b>Clean and Repack Interval</b>		5 Years	3 Years	2 Years	1 Year

\* Additional bearing protection or special sealing may be required. Consult Regal Rexnord Bearing Division.

Suggested starting interval for maintenance program. Check grease condition for oiliness and dirt and adjust greasing frequency accordingly. Watch operating temperatures. Sudden rises may show need for grease or indicate over lubrication on higher speed applications.



## OIL LUBRICATION

**Oil Cup or Oil Bath Lubrication** — Oil cups can be applied for use as a self-contained oil bath system. Oil bath lubrication is not recommended for speeds above the catalog oil speed limits, where excessive oil churning or misting occurs, or where there is air flow across the housing, which will pull oil out through the seals due to different pressures.

Oil levels are controlled by sight gages, oil cups, etc. These should be used in conjunction with a vent or breather cap. Proper static oil levels are shown in **Table 5**. Cups or sight gages should be carefully marked.

**Circulating Oil Lubrication (See Page 9)** — Oil circulation systems can be used under a wider variety, or under more extreme operating conditions than any other lubrication method. They are especially valuable for high speed and high temperature service to provide better lubrication and cooler operation.

A complete circulation system includes the use of pressure pump, a heat exchanger (or a method of cooling oil), an adequate sump, a filter to remove particles over 20 micron in size and safety devices such as pressure and temperature warning devices and filter bypasses. It is also best to tap oversize drain holes in the housing or to provide a suction pump to positively remove oil from the housing. Oil should be removed from both sides of the housing, but where speeds are not high one side may be sufficient.

**Oil Viscosity** — The required viscosity for good lubrication depends on starting temperatures, operating temperatures, and speed. The recommended viscosity level for bearings operating within catalog speed limits is between 100 and 150 Saybolt seconds (SSU) at operating temperature for oil exit temperature on circulating systems. Slow speed heavily loaded bearings require much higher viscosities. Consult Regal Rexnord™ Bearing Division.

Where starting temperatures are very low compared to operating temperatures, heaters may be necessary to provide oil flow in the lines or to provide adequate lubrication at start-up.

**Maintenance and Lubrication** — Oil cup or oil bath systems require close attention because of the limited amount of oil in the system. Frequent changing of oil is necessary in these systems to avoid lubricant breakdown. Oil circulating systems, properly equipped with safety devices, require minimum attention after they are once satisfactorily adjusted. Frequency of changing the oil in the system depends upon the severity of the operation and size of the reservoir. Also, summer and winter grades of oil may be required, to stay within the recommended viscosity limits for good lubrication.

**TABLE 5 – Static Oil Level (See Figure 10 on Page 9)**

Block Number	A	D	L	
			High	Low
Inches				
<b>6823, 6824</b>	2 1/4	7/16	1 9/32	1 3/8
<b>6827, 6828</b>	2 1/2	9/16	1 3/8	1 15/32
<b>6831, 6832</b>	2 3/4	9/16	1 17/32	1 5/8
<b>6835, 6836</b>	3	1/2	1 27/32	1 15/16
<b>6839</b>	3 1/4	5/8	2 1/32	2 1/4
<b>6843</b>	3 1/2	3/4	2 3/16	2 9/32
<b>6847, 6848</b>	3 3/4	13/16	2 3/16	2 15/32
<b>6851</b>	4	3/4	2 15/32	2 5/8
<b>6855, 6856</b>	4 1/2	7/8	2 25/32	2 15/16
<b>6859-6864</b>	4 15/16	7/8	3 1/16	3 7/32
<b>6867</b>	5 1/4	1	3 5/16	3 1/2
<b>6871, 6872</b>	6	1 1/4	3 9/16	3 3/4
<b>6879, 6880</b>	6	1 1/16	3 7/8	4 1/16
<b>6883</b>	6 5/16	1 1/16	4 5/32	4 11/32
<b>6887</b>	6 11/16	1	4 15/32	4 21/32
<b>6895, 6896</b>	7 1/16	1 1/8	4 3/4	4 15/16
<b>68103</b>	7 1/2	1 1/8	4 31/32	5 9/32
<b>68111, 68112</b>	7 7/8	1 1/4	5 1/4	5 7/16
<b>68115</b>	8 1/4	1 3/8	5 9/16	5 3/4
<b>68120-68128</b>	9 1/2	2 1/2	6 5/32	6 11/32
<b>66135-66144</b>	8 1/4	1 3/8	5 15/16	6 1/8
<b>66B151, 66B152</b>	9 1/2	1 1/2	6 15/16	7 1/8
<b>66159, 66160</b>	9 1/2	1 1/2	6 15/16	7 1/8
<b>66167, 66168</b>	9 1/2	1 1/2	6 15/16	7 1/8
<b>66175, 66176</b>	12	2 7/8	7 17/32	7 23/32
<b>6923, 6924</b>	2 3/4	11/16	1 7/16	1 17/32
<b>6927</b>	3	9/16	1 19/32	1 11/16
<b>6931, 6932</b>	3 1/4	13/16	1 23/32	1 13/16
<b>6935</b>	3 1/2	3/4	2 1/32	2 5/32
<b>6939, 6940</b>	4	3/4	2 11/32	2 1/2
<b>6943</b>	4 1/4	7/8	2 15/32	2 5/8
<b>6947</b>	4 1/2	7/8	2 23/32	2 13/16
<b>22618</b>	4 3/4	1 3/32	2 25/32	2 31/32
<b>22620</b>	5 1/4	1	3 1/8	3 5/16
<b>22622</b>	6	1 1/4	3 15/32	3 21/32
<b>22624</b>	6 5/16	1 3/16	3 25/32	3 31/32
<b>22626</b>	6 11/16	1 1/16	4 3/32	4 9/32
<b>22628</b>	7 1/16	1 3/16	4 3/8	4 9/16
<b>22630</b>	7 1/2	1 3/16	4 11/16	4 7/8
<b>22632</b>	7 7/8	1 5/16	4 31/32	5 5/32

## D5 SEAL ARRANGEMENT

### PENTAC D-5 SEALING SYSTEM

1. Before installing the bearing, slide 1st rubber PenTac Seal on shaft. If hard to do so, coat shaft and seal bore with a thin layer of oil. If oil is used, the shaft must be wiped clean.
2. Pack the grease cavity of the rubber seal with grease using a flexible putty knife. See **Figure 5** for reference.
3. Assembly bearing referring to Adapter Mounted Units page 1-2.
4. Slide on second rubber PenTac seal. Repeat steps 1 and 2.
5. Slowly push each seal so the lip rests lightly against the housing. You can be sure by seeing a slight flex in the lip seal.
6. Use a marker and mark the shaft right behind the heel of the seal. Refer to **Figure 6**.
7. Push the seal in by distance given in **Table 6** (**Figure 7**).

**TABLE 6 — Distance to Push Seal Inward**

Shaft Size	Push in Distance 1 mm	Push in Distance 2 mm
1 7/16- 1 1/2", 40mm	5300 > RPM > 2700	< 2700 RPM
1 11/16 - 1 3/4", 45mm	5000 > RPM > 2400	< 2400 RPM
1 15/16 - 2", 50mm	4500 > RPM > 2300	< 2300 RPM
2 3/16", 60mm	3800 > RPM > 2200	< 2200 RPM
2 7/16", 65mm	3400 > RPM > 2000	< 2000 RPM
2 11/16", 70mm	3200 > RPM > 1800	< 1800 RPM
2 15/16 - 3", 75mm	3000 > RPM > 1700	< 1700 RPM
3 3/16", 80mm	2600 > RPM > 1500	< 1500 RPM
3 7/16 - 3 1/2", 90mm	2200 > RPM > 1500	< 1500 RPM
3 11/16 - 4", 100mm	2000 > RPM > 1300	< 1300 RPM
4 3/16", 110mm	1900 > RPM > 1200	< 1200 RPM
4 7/16 - 4 1/2", 115mm	1800 > RPM > 1150	< 1150 RPM
4 15/16 - 5", 125mm	1700 > RPM > 1000	< 1000 RPM
5 3/16", 135mm	1600 > RPM > 950	< 950 RPM
5 7/16", 140mm	1500 > RPM > 950	< 950 RPM
5 15/16 - 6", 150mm	1300 > RPM > 850	< 850 RPM
6 7/16", 160mm	1300 > RPM > 800	< 800 RPM
6 15/16" - 7", 170mm	1200 > RPM > 750	< 750 RPM
7 3/16", 180mm	1100 > RPM > 700	< 700 RPM
7 1/2 - 8", 200mm	1000 > RPM > 650	< 650 RPM
8 7/16 - 9", 220mm	1000 > RPM > 550	< 550 RPM
9 7/16 - 10 1/2", 260mm	850 > RPM > 500	< 500 RPM

**Figure 5 — Cross section of rubber PenTac seal member**

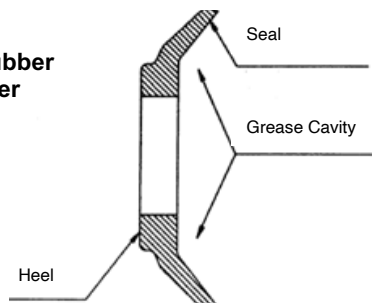

## ADDITIONAL INSTALLATION COMMENTS

1. PenTac Seal is made of nitrile rubber and can be cleaned with certain solvents. Some solvents can cause damage to the seal. For questions on a specific solvent, contact Regal Rexnord™.
2. When sliding seal onto shaft, use light impact blows on the heel on the seal. Do not impact the seal lip.
3. If the bearing will experience extreme temperatures (>170°F) due to environment and system conditions, the "Push In" distance of 1mm should be used regardless of shaft speed.
4. If seal is pushed in too far, place a screwdriver between seal lip and housing. While maintaining pressure against the housing, rotate handle upward.

**Figure 6 — Complete assembly of D-5 PenTac showing reference line drawn on the shaft.**

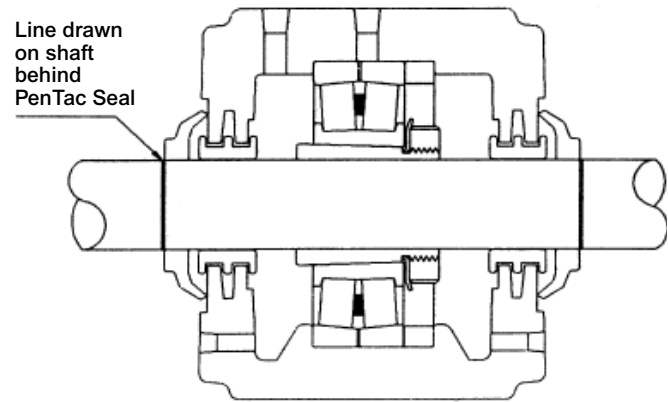

**Figure 7 — Installed "Push In" distance shown at the final installed position of the PenTac Seal.**

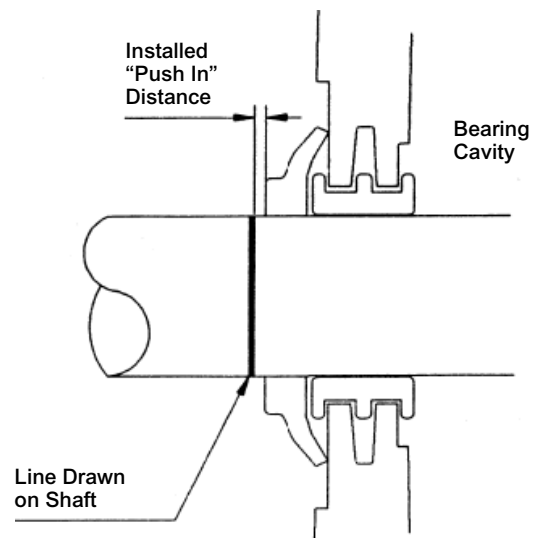

## D8 SEAL ARRANGEMENT

### D8 (or D9) TACONITE SEALING SYSTEM

1. Before installing the bearing, slide 1st Seal Carrier on shaft.
2. Assembly bearing referring to Adapter Mounted Units **Page 1-2**. Slide on 2nd seal carrier.
3. Seal carrier internal cavities should be fully packed with grease before assembly on shaft.
4. The packing ring in the seal carrier O.D. groove should be positioned in the middle to outboard half of the groove.
5. **The seal carriers must be rotated so that the carrier anti rotation tang fits into the slot provided in the housing base interior side wall.**

## ADDITIONAL INSTALLATION COMMENTS

1. D8 and D9 Sealing systems require a specially machined groove in the housings. The taconite seals cannot be used with a standard LER ring housing groove.
2. As a starting point, a factor of 0.5 times the shaft diameter gives the approximate cubic inch volume of grease to flush one seal assembly.

Figure 8 — Instruction Decal

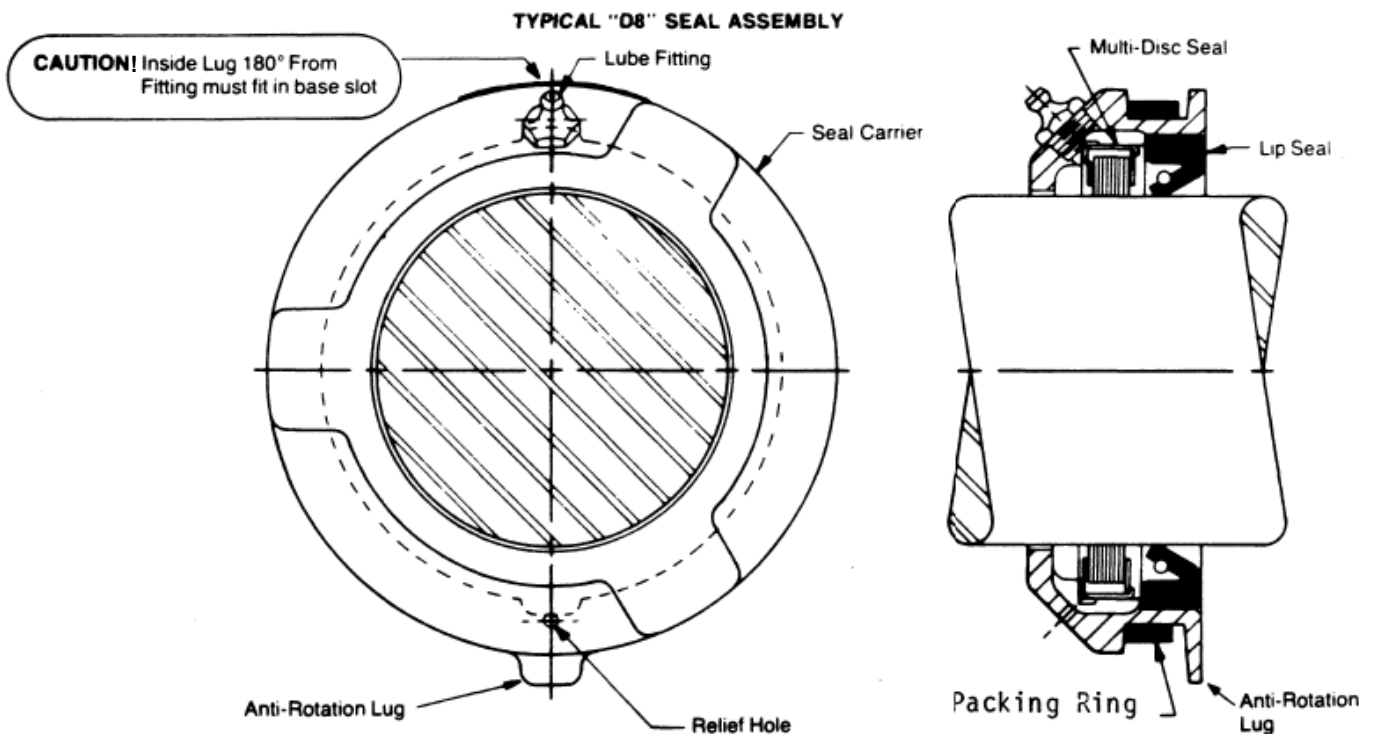

## SERIES 7600, 7800, 7900

### DIRECT SHAFT MOUNT UNITS (7600, 7800, 7900)

1. Inspect shaft size. Clean shaft and mounting surface as needed.
2. Position housing base onto mounting surface. Snug down mounting bolts.
3. Slide on first seal. If “B” felt seals are used, hold until step 8.
4. Mount all inboard items on shaft. Coat shaft bearing seat with a mixture of white lead and oil or suitable solid lubricant. Start bearing squarely on shaft. Apply pressure to the inner ring only. A soft steel tube or pipe having an O.D. no larger than the inner ring shoulder may be used to press or tap the bearing into position. Bearings may be shrink fitted on the shaft by heating evenly in oil to 250°F max. Slip the thoroughly heated bearing onto the shaft and hold in position until it cools and shrinks on the shaft.
5. Install and tighten locknut and lockwasher or other holding device securely. A lockwasher tang must be bent over into a notch in the locknut or lockwire heads of capscrews holding the lock plate.
6. Check for freedom of rotation to ensure operating clearance has not been removed by shaft fit.
7. Force grease in one side of the bearing until it comes out the other side all the way around. Fill grease reservoir on both sides to the bottom of the shaft. See Lubrication Information **Table 8**, for more information.
8. If felt seal halves are not fastened to the cap with adhesive this should be done. Dry the seal grooves in both sides of the cap to remove oil and preservative. Apply a good quality rubber cement evenly to both the seal O.D. and the housing seal bore. Do not get adhesive on the felt. When adhesive dries to slight tackiness, install the seal halves in the cap. Install the other halves in the base before the shaft is in place, then wet the felts with oil. The shaft holds seals in place for complete drying. Do not operate until adhesive is set.
9. For oil lubricated bearings, apply non-hardening gasket compound to cap surfaces which contact the base (Not needed for grease lubrication).
10. With the mounting bolts snug, check the alignment and freedom of rotation. **“B” seals:** Visually check the clearance between the shaft and the bore of the seal. This clearance is small and can be visually checked for uniformity all the way around the seal. **“R” or “H” seals:** Measure the distance between the outside diameter of the seal and the diameter of the housing counterbore in three places. Be sure that each measurement is taken 90 degrees from the previous measurement. All three measurements should be uniform to insure proper alignment. See **Figure 9**. Align by shimming or shifting as necessary. Use large area shims to avoid distorting the housing and pinching the bearing. Appropriate use

of stop bars against faces or ends of feet opposite the direction of load or vibration to avoid shifting of the housing is recommended. Dowel pins can be equally effective if properly used. This is especially important where loads are not directly down through the base. Finally, tighten or torque mounting bolts securely. Up to SAE Grade 5 mounting bolts can be used, properly torqued, to mount cast iron housings (See **Table 7A**). Up to SAE Grade 8 mounting bolts can be used, properly torqued, to mount cast steel housings (See **Table 7B**).

### ADDITIONAL INSTALLATION COMMENTS

1. Cap and base are machined as matched unit and are not interchangeable. The machined split line on base is marked and should be matched to corresponding cap.
2. If outer rings become misaligned, do not force back into position. Instead, carefully work back by turning and sliding.

**Figure 9 —  
Checking Alignment**

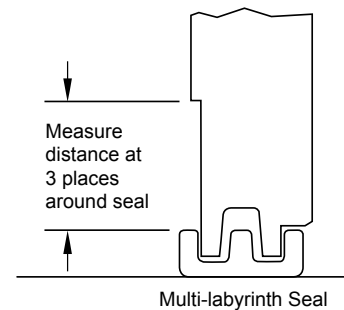

**TABLE 7A — Recommended Housing Cap Bolt Tightening Torque**

CAST IRON HOUSING			
Series 7800	Series 7600	Series 7900	Tightening Torque (lb-ft / N-m)
7875	...	7945-7955	45-50 / 61-68
7880-7890	...	7965-7980	90-100 / 122-136
78100-78130	...	7985-22322	160-180 / 217-245
78140-78180	...	22324-22330	400-440 / 542-597
78190-78200	76240	22332-22334	630-700 / 854-950
78220	76280	...	800-890 / 1085-1207
...	76300	...	1400-1550 / 1900-2102

**TABLE 7B — Recommended Housing Cap Bolt Tightening Torque**

CAST STEEL HOUSING*			
Series 7800	Series 7600	Tightening Torque (lb-ft / N-m)	
		Load Directed into Base	Load Directed into Cap*
7875	...	50-65 / 68-88	80-110 / 109-149
7880-7885	...	100-130 / 135-176	160-220 / 217-298
7890-78110	...	170-230 / 230-312	300-400 / 407-543
78120-78130	...	280-370 / 380-502	490-650 / 665-882
78140	...	410-550 / 556-746	730-970 / 990-1315
78150-78180	76240	580-780 / 787-1058	1030-1370 / 1397-1858
78190-78200	76280	820-1100 / 1112-1492	1450-1940 / 1966-2630
78220	76300	1430-1900 / 1940-2576	2530-3370 / 3430-4570
...	...	1400-1550 / 1900-2102	2530-3370 / 3430-4570

\* Replace spring lockwasher with plain washer.

**GREASE LUBRICATION** is recommended wherever conditions in Table 8 exist. For conditions which are not completely covered in Table 8 consult Regal Rexnord™ Bearings Division. A reputable lubricant manufacturer should be consulted to confirm the lubricant selection and application.

**Relubrication After Running** — Relubrication of units in service should be through the fitting or hole in the center of the unit when bearings with lube holes and grooves are used as normally supplied. The amount of grease used should be enough to purge old grease from the bearing only (not the entire pillow block) and form a cushion of grease adjacent to the bearing face.

**High Speed Operation** — Consult Table 8 for a guide to correct greases and frequency of relubrication. High speed bearings will not operate satisfactory when packed full of grease. As relubrication will eventually fill the housing cavities, it may be necessary to remove the cap periodically, clean out the old lubricant and repack with the original amount.

Regal Rexnord Bearing Division, cannot be held responsible for performance of individual batches of grease. Changes in lubricant specifications, performance, and lubricant guarantees are the responsibility of the lubricant manufacturer.

- Operating temperature limited to -40 to +225°F
- “Dirty,” Corrosive or Wet environments require more frequent re-lube
- D8 seal limit is 1500 surface feet per minute
- B felt seal limit is 800 surface feet per minute
- Reduce lubrication intervals by half for vertical shaft applications

**TABLE 8 — Lubrication Information**

LUBRICATION TABLE (HORIZONTAL SHAFT APPLICATION)					
7800/7600 Series Shaft Size	To Relubricate Units	RECOMMENDED NUMBER OF MONTHS BETWEEN RELUBRICATION* (BASED ON 24/7 OPERATION)			
		Relube Interval			
		6 Months	4 Months	2 Months	1 Month
75 mm	0.40 oz.	1450	2200	3000	3400
80 mm	0.45 oz.	1350	2000	2800	3200
85 mm	0.60 oz.	1300	1900	2600	3000
90 mm	0.85 oz.	1200	1800	2400	2700
100 mm	1.15 oz.	1100	1650	2200	2300
110 mm	1.60 oz.	1000	1500	1950	2100
120 mm	2.15 oz.	900	1350	1850	1900
130 mm	2.80 oz.	840	1250	1700	1800
140 mm	3.20 oz.	780	1150	1600	1700
150 mm	4.00 oz.	730	1100	1500	1600
160 mm	5.10 oz.	680	1000	1400	1500
170 mm	6.10 oz.	640	970	1300	1400
180 mm	6.40 oz.	610	910	1200	1300
190 mm	7.70 oz.	570	860	1100	1200
200 mm	11.70 oz.	550	820	1000	1100
220 mm	13.40 oz.	500	750	900	1000
		Shaft Speed in RPM			
<b>Clean and Repack Interval</b>		5 Years	3 Years	2 Years	1 Year

7900/SAF22300 Series Shaft Size	To Relubricate Units	RECOMMENDED NUMBER OF MONTHS BETWEEN RELUBRICATION* (BASED ON 24/7 OPERATION)			
		Relube Interval			
		6 Months	4 Months	2 Months	1 Month
45 mm	0.35 oz.	1325	2100	3150	4200
50 mm	0.55 oz.	1200	1900	2850	3800
55 mm	0.65 oz.	1075	1800	2700	3600
60 mm	0.95 oz.	925	1500	2250	3000
70 mm	1.30 oz.	800	1300	1950	2600
80 mm	1.60 oz.	750	1250	1875	2500
85 mm	1.80 oz.	700	1150	1725	2300
90 mm	2.15 oz.	650	1100	1650	2200
100 mm	3.10 oz.	600	1000	1500	2000
110 mm	4.15 oz.	550	900	1350	1800
120 mm	5.80 oz.	500	800	1200	1600
130 mm	6.70 oz.	450	750	1125	1500
140 mm	8.45 oz.	425	700	1050	1400
150 mm	11.00 oz.	400	650	975	1300
160 mm	13.00 oz.	375	625	950	1250
170 mm	15.50 oz.	350	575	850	1150
		Shaft Speed in RPM			
<b>Clean and Repack Interval</b>		5 Years	3 Years	2 Years	1 Year

\* Additional bearing protection or special sealing may be required. Consult Regal Rexnord Bearing Division.

Suggested starting interval for maintenance program. Check grease condition for oiliness and dirt and adjust greasing frequency accordingly. Watch operating temperatures. Sudden rises may show need for grease or indicate over lubrication on higher speed applications.



## SERIES 6600, 6800, 6900, 7600, 7800, 7900

### CIRCULATING OIL LUBRICATION INFORMATION

**Circulating Oil Lubrication** — Oil circulation systems can be used under a wider variety, or under more extreme operating conditions than any other lubrication method. They are especially valuable for high speed and high temperature service to provide better lubrication and cooler operation.

A complete circulation system includes the use of pressure pump, a heat exchanger (or a method of cooling oil), an adequate sump, a filter to remove particles over 20 micron in size and safety devices such as pressure and temperature warning devices and filter bypasses. It is also best to tap oversize drain holes in the housing or to provide a suction pump to positively remove oil from the housing. Oil should be removed from both sides of the housing, but where speeds are not high one side may be sufficient. See **Figure 10** for Schematic.

**Oil Viscosity** — The required viscosity for good lubrication depends on starting temperatures, operating

temperatures, and speed. The recommended viscosity level for bearings operating within catalog speed limits is between 100 and 150 Saybolt seconds (SSU) at operating temperature for oil exit temperature on circulating systems. Slow speed heavily loaded bearings require much higher viscosities. Consult Regal Rexnord™ Bearing Division.

Where starting temperatures are very low compared to operating temperatures, heaters may be necessary to provide oil flow in the lines or to provide adequate lubrication at start-up.

**Maintenance and Lubrication** — Oil cup or oil bath systems require close attention because of the limited amount of oil in the system. Frequent changing of oil is necessary in these systems to avoid lubricant breakdown. Oil circulating systems, properly equipped with safety devices, require minimum attention after they are once satisfactorily adjusted. Frequency of changing the oil in the system depends upon the severity of the operation and size of the reservoir. Also, summer and winter grades of oil may be required, to stay within the recommended viscosity limits for good lubrication.

**Figure 10 — Schematic Diagram of Circulation Oil System**

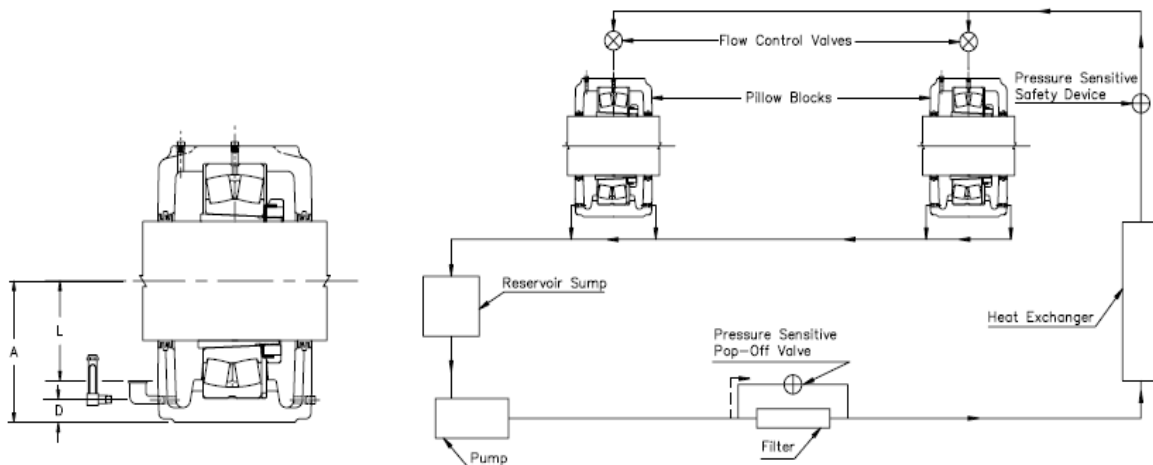

A. IT IS EXPRESLY AGREED THAT THE FOLLOWING WARRANTY IS GIVEN IN LIEU OF ALL OTHER WARRANTIES, WHETHER EXPRESSLY IMPLIED OF STATUTORY. INCLUDING THOSE OF **MERCHANTABILITY** AND FITNESS FOR A PATICULAR PURPOSE, AND OF ANY OTHER OBLIGATION OR LIABILITY ON OR PART OF ANY KIND OR NATURE WHATSOEVER.

No representative of ours has any authority to waive, alter, vary, or add to the terms hereof without prior approval in writing, to our customer, signed by an officer of our company. It is expressly agreed that the entire warranty given to the customer is embodied in this writing. This writing constitutes the final expression of the parties agreement with respect to warranties, and that it is a complete and exclusive statement of the terms of the warranty.

We warrant to our customers that all Products manufactured by us will be free from defects in material and workmanship at the time of shipment to our customer for a period of one (1) year from the date of shipment. All warranty claims must be submitted to us within ten days of discovery of defects within the warranty period, or shall be deemed waived. As to Products or parts thereof that are proven to have been defective at the time of shipment, and that were not damaged in shipment, the sole and exclusive remedy shall be repair or replacement of the defective parts or repayment of the proportionate purchase price for such Products or part, at our option. Replacement parts shall be shipped free of charge f.o.b. from our factory.

This warranty shall not apply to any Product which has been subject to misuse; misapplication, neglect (including but not limited to improper maintenance and storage); accident, improper installation, modification (including but not limited to use of unauthorized parts or attachments), adjustment, repair or lubrication. Misuse also includes, without implied limitation, deterioration in the Product or part caused by chemical reaction, wear caused by the presence of abrasive materials, and improper lubrication. Identifiable items manufactured by others but installed in or affixed to our Products are not warranted by use but, bear only those warranties, express or implied, given by the manufacturer of that item, if any. Responsibility for system design to insure proper use and application of Link-Belt® Products within their published specifications and ratings rests solely with customer. This includes without implied limitation analysis of loads created by torsional vibrations within the entire system regardless of how induced.

B. It is expressly agreed that our liability for any damage arising out of or related to this transaction, or the use of our Products, whether in contract or in tort, is limited to the repair or replacement of the Products, or the parts thereof by use, or to a refund of the proportionate purchase price. We will not be liable for any other injury, loss, damage, or expense, whether direct or consequential, including but not limited to use, income, profit, production, or increased cost of operation, or spoilage of or damage to material, arising in connection with the sale, installation, use of, inability to use, or the replacement of, or late delivery of, our Products.