



ELECTRIC MOTORS, GEARMOTORS AND DRIVES

SPEEDMASTER™

SCR THYRISTOR MOTOR CONTROLS

Catalog Numbers

**174100, 174105, 174307, 174308, 174311, 174709,
M1740005, M1740006, M1740007**

OPERATION MANUAL

LIMITED WARRANTY

A. Warranty - Leeson Electric Corporation (referred to as "the Corporation") warrants that its products will be free from defects in material and workmanship for a period of one (1) year from the date of shipment thereof. Within the warranty period, the Corporation will repair or replace such products that are returned to Leeson Electric Corporation or to the nearest Branch Office, with shipping charges prepaid. At our option, all return shipments are F.O.B. Leeson Electric or its Branch Office. This warranty shall not apply to any product that has been subject to misuse, negligence, or accident; or misapplied; or repaired by unauthorized persons; or improperly installed. The Corporation is not responsible for removal, installation, or any other incidental expenses incurred in shipping the product to or from the repair point.

B. Disclaimer - The provisions of Paragraph A are the Corporation's sole obligation and exclude all other warranties of MERCHANTABILITY or use, express or implied. The Corporation further disclaims any responsibility whatsoever to the customer or any other persons for injury to person or damage or loss of property of value caused by any product that has been subject to misuse, negligence, or accident, or misapplied or modified by unauthorized persons or improperly installed.

C. Limitations of Liability - In the event of any claim or breach of any of the Corporation's obligations, whether expressed or implied, and particularly of any claim of a breach of warranty claimed in Paragraph A, or of any other warranties, express, or implied, or claim of liability that might, despite Paragraph B, be decided against us by any lawful authority, the Corporation shall under no circumstances be liable for any consequential damages, losses, or expense arising in connection with the use of, or inability to use, the Corporation's product for any purpose whatsoever. An adjustment made to the warranty does not void the warranty, nor does it imply an extension of the original one (1) year warranty period. Product serviced and/or parts replaced by a no-charge basis during the warranty period carry the unexpired portion of the original warranty only.

If for any reason any of the forgoing provisions shall be ineffective, the Corporation's liability for damages arising out of its manufacture or sale of equipment, or use thereof, whether such liability is based on warranty, contract, negligence, strict liability in tort, or otherwise, shall not in any event exceed the full purchase of such equipment.

Any action against the Corporation based upon any liability or obligation arising hereunder or under any law applicable to the sale of equipment or the use thereof must be commenced within one year after the cause of such action arises.

Safety Warnings



- This symbol  denotes an important safety tip or warning. Please read these instructions carefully before performing any of the procedures contained in this manual.
- **DO NOT INSTALL, REMOVE, OR REWIRE THIS EQUIPMENT WITH POWER APPLIED.** Have a qualified electrical technician install, adjust and service this equipment. Follow the National Electrical Code and all other applicable electrical and safety codes, including the provisions of the Occupational Safety and Health Act (OSHA), when installing equipment.
- Reduce the chance of an electrical fire, shock, or explosion by proper grounding, over-current protection, thermal protection, and enclosure. Follow sound maintenance procedures.



Warning

It is possible for a drive to run at full speed as a result of a component failure. Leeson strongly recommends the installation of a master switch in the main power input to stop the drive in an emergency.

Circuit potentials are at 115 VAC or 230 VAC above earth ground. Avoid direct contact with the printed circuit board or with circuit elements to prevent the risk of serious injury or fatality. Use a non-metallic screwdriver for adjusting the calibration trimpots. Use insulated tools if working on this drive with power applied.

Contents

Specifications	1
Dimensions	3
Installation	10
Chassis (uncased) drive installation	10
Mounting	10
Wiring	11
Shielding guidelines	12
Heat sinking	13
Line fusing	13
Speed adjust potentiometer	15
Connections	16
Motor	16
Power input	17
Line fuse	17
Voltage follower	19
Cased drive installation	20
Mounting (NEMA 1 enclosures)	20
Mounting (NEMA 4 and NEMA 4/12 enclosures)	21
Heat sinking	22
Line fusing	23
Connections	23
Operation	25
Before applying power	25
Startup	26
174311 and M1740007	26
174100, 174307, 174709, and M1740005	26
174308 and M1740006	27
174105	28

All drives	29
Starting and Stopping Methods	30
Line starting and line stopping	30
Inhibit circuit	31
Decelerating to minimum speed	32
Dynamic braking	33
Sizing the dynamic brake resistor	34
Calibration	35
Calibration procedure	37
MINIMUM SPEED (MIN SPD)	37
MAXIMUM SPEED (MAX SPD)	38
REGULATION (IR COMP)	38
TORQUE LIMIT (TORQUE)	39
ACCELERATION (ACCEL)	40
DECELERATION (DECEL)	40
Calibration procedure conclusion	40
Application Notes	43
Multiple fixed speeds	43
Adjustable speeds using potentiometers in series	44
Independent adjustable speeds	45
RUN/JOG switch	46
RUN/JOG option #1	46
RUN/JOG option #2	47
Reversing	48
Troubleshooting	49
Before troubleshooting	49
Current limit LED (174011 and M1740007)	50

Illustrations

Figure 1.	174311 and M1740007 Dimensions	3
Figure 2.	174307 and M1740005 Dimensions	4
Figure 3.	174308 and M1740006 Dimensions	5
Figure 4.	174100 Dimensions	6
Figure 5.	174105 Dimensions	7
Figure 6.	174709 Dimensions	8
Figure 7.	Heat Sink Dimensions	9
Figure 8.	Speed Adjust Potentiometer	15
Figure 9.	Chassis Drive Connections	18
Figure 10.	Voltage Follower Connections	19
Figure 11.	NEMA 1 Mounting Hole Locations	21
Figure 12.	Cased Drive Connections	24
Figure 13.	174709 Connections	24
Figure 14.	Voltage Switches	25
Figure 15.	Inhibit Plug with Run/Coast to Minimum Speed Switch	31
Figure 16.	Run/Decelerate to Minimum Speed Switch	32
Figure 17.	Dynamic Brake Connection	33
Figure 18.	Calibration Trimpot Layout	36
Figure 19.	Recommended TORQUE and IR COMP Settings	41
Figure 20.	Recommended TORQUE and IR COMP Settings for 174109 Series Controls	42
Figure 21.	Multiple Fixed Speeds	43
Figure 22.	Adjustable Fixed Speeds Using Potentiometers in Series	44
Figure 23.	Independent Adjustable Speeds	45
Figure 24.	RUN/JOG Switch Option #1	46
Figure 25.	RUN/JOG Switch Option #2	47
Figure 26.	Reversing Circuit Connection	48
Figure 27.	Current Limit LED	50

Tables

Table 1.	Recommended Line Fuse Sizes	14
Table 2.	Field Output Connections	17
Table 3.	Recommended Dynamic Brake Resistor Sizes	34

Specifications

Model	Max. Armature Current (Amps DC)	HP Range with 115 VAC Applied	HP Range with 230 VAC Applied	Style
M1740007	1.5	1/20–1/8		Chassis
M1740005				NEMA 1
M1740006				NEMA 4X
174311 †	5.0	1/8–1/2	1/4–1	Chassis
174307 ‡				NEMA 1
174308 ‡				NEMA 1
174100	10.0	1/8–1	1/4–2	NEMA 4X
174105				NEMA 4X
174709	15	1 – 1.5	2 – 3	NEMA 4X

† Double maximum armature current and horsepower when drive is mounted on heat sink part number 174314.

‡ Double maximum armature current and horsepower when drive is mounted on heat sink part number 174316.

AC Line Voltage 115 VAC or 230 VAC $\pm 10\%$, 50/60 Hz, single phase

Armature Voltage

115 VAC Input 0–90 VDC

230 VAC Input 0–180 VDC

Field Voltage

115 VAC Input 50 VDC (F1 to L1); 100 VDC (F1 to F2)

230 VAC Input 100 VDC (F1 to L1); 200 VDC (F1 to F2)

Max. Field Current 1 ADC

Form Factor 1.37 at base speed

Accel. Time Range

0–90 VDC Armature Voltage 0.5–11 seconds

0–180 VDC Armature Voltage	0.5–22 seconds
Decel. Time Range	
0-90 VDC Armature Voltage	coast to a stop–13 seconds
0–180 VDC Armature Voltage	coast to a stop–25 seconds
Analog Input Voltage Range (signal must be isolated; S1 to S2)	
0–90 VDC Armature Voltage	0–1.4 VDC
0–180 VDC Armature Voltage	0–2.8 VDC
Input Impedance (S1 to S2)	100K ohms
Load Regulation	1% base speed or better
Vibration	0.5G max (0–50 Hz) 0.1G max (>50 Hz)
Safety Certification	UL Recognized Component, file # E132235 CSA Certified Component, file # LR41380 CE Certificate of Compliance
Ambient Temp. Range	
chassis drive	10°C–55°C
cased drive	10°C–40°C

Dimensions

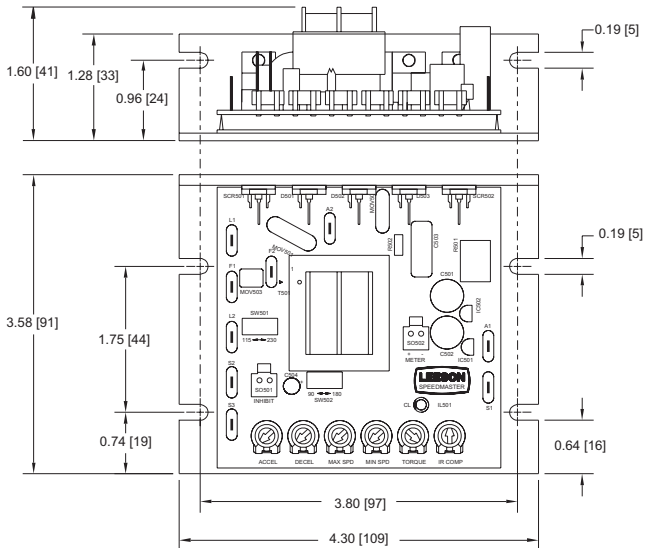

ALL DIMENSIONS IN INCHES [MILLIMETERS]

Figure 1. 174311 and M1740007 Dimensions

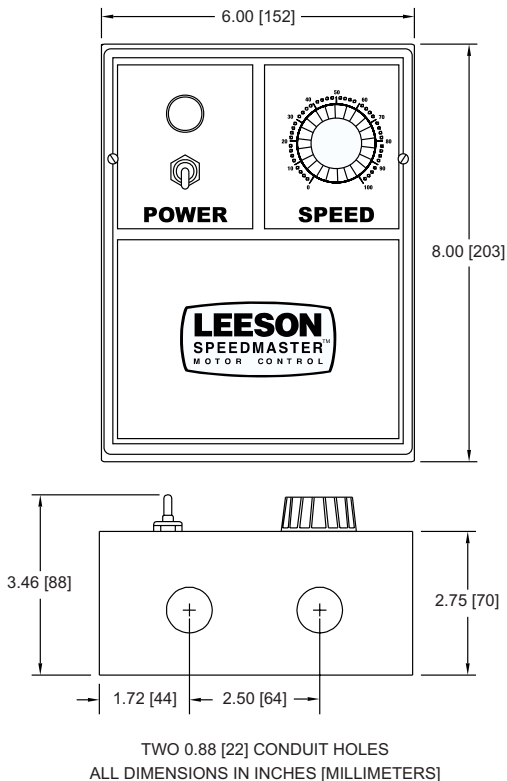
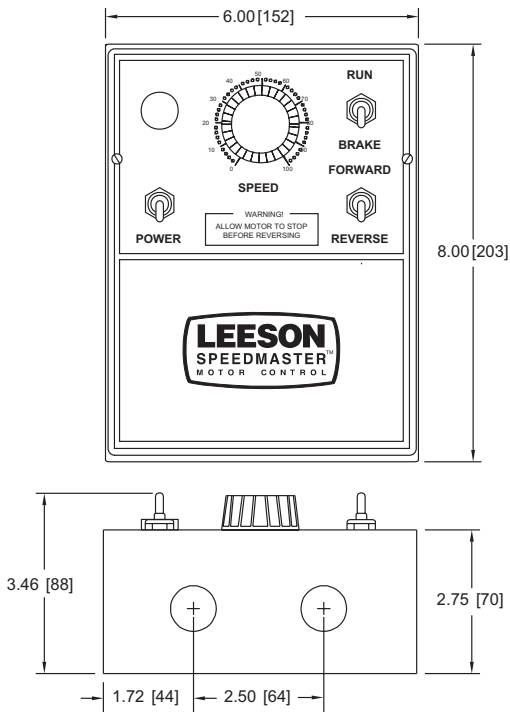
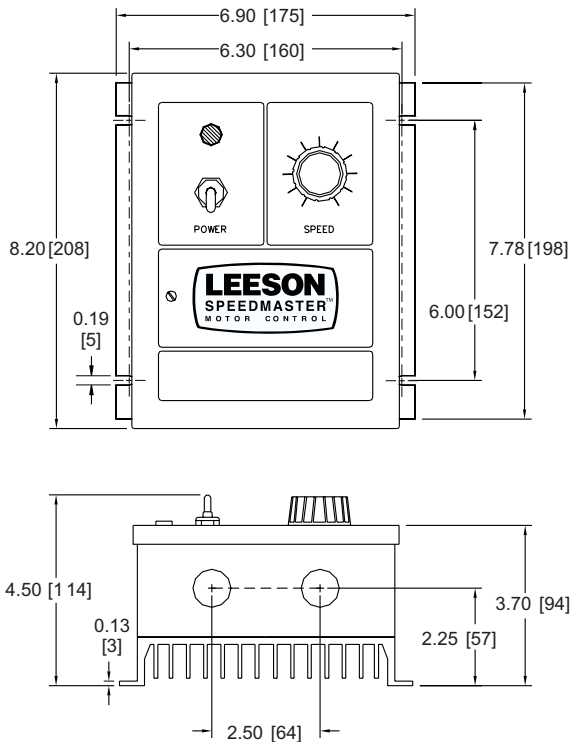

Figure 2. 174307 and M1740005 Dimensions



TWO 0.88 [22] CONDUIT HOLES
ALL DIMENSIONS IN INCHES [MILLIMETERS]

Figure 3. 174308 and M1740006 Dimensions



TWO 0.88 [22] KNOCKOUTS
ALL DIMENSIONS IN INCHES [MILLIMETERS]

Figure 4. 174100 Dimensions

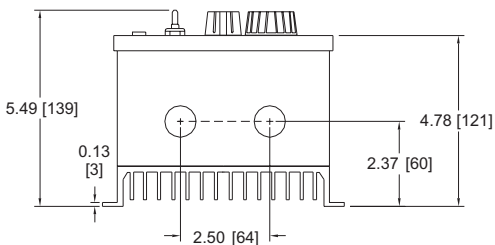
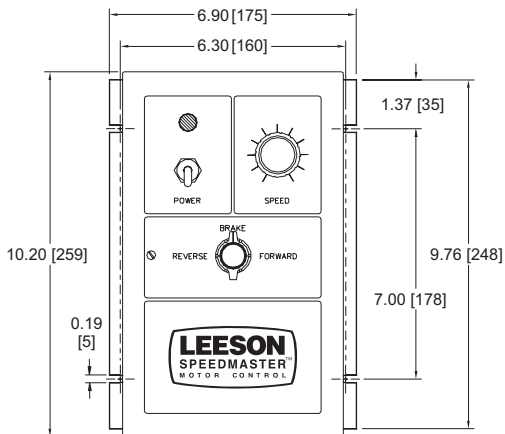

TWO 0.88 [22] KNOCKOUTS
ALL DIMENSIONS IN INCHES [MILLIMETERS]

Figure 5. 174105 Dimensions

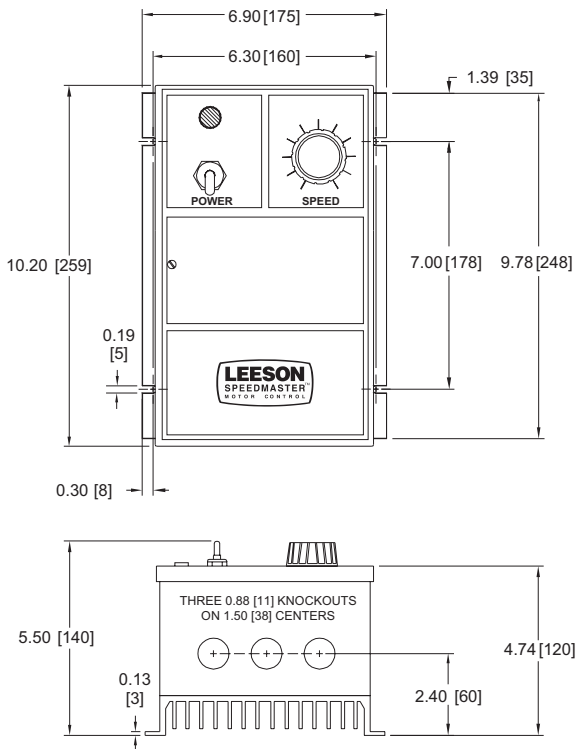

ALL DIMENSIONS IN INCHES [MILLIMETERS]

Figure 6. 174709 Dimensions

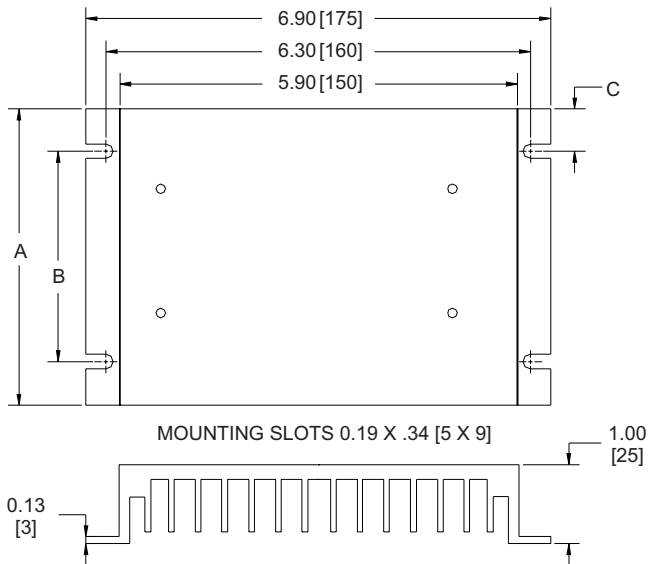

PART NO.	DIM "A"	DIM "B"	DIM "C"
174314	4.40 [112]	3.00 [76]	0.7 [18]
174316	7.78 [198]	6.00 [152]	0.89 [23]

Heat sinks sold separately.

ALL DIMENSIONS IN INCHES [MILLIMETERS]

Figure 7. Heat Sink Dimensions

Installation

Chassis (uncased) drive installation

Mounting

- Drive components are sensitive to electrostatic fields. Avoid contact with the circuit board directly. Hold drive by the chassis only.
- Protect the drive from dirt, moisture, and accidental contact.
- Provide sufficient room for access to the terminal block and calibration trimpots.
- Mount the drive away from other heat sources. Operate the drive within the specified ambient operating temperature range.
- Prevent loose connections by avoiding excessive vibration of the drive.
- Mount drive with its board in either a horizontal or vertical plane. Six 0.19 in. (5 mm) wide slots in the chassis accept #8 pan head screws. Fasten either the large base or the narrow flange of the chassis to the subplate.
- The chassis does not have to be earth grounded. If you choose to ground the chassis, use a star washer beneath the head of at least one of the mounting screws to penetrate the anodized chassis surface and to reach bare metal.

Wiring



Warning



Do not install, remove, or rewire this equipment with power applied. Failure to heed this warning may result in fire, explosion, or serious injury.

Circuit potentials are at 115 VAC or 230 VAC above ground. To prevent the risk of injury or fatality, avoid direct contact with the printed circuit board or with circuit elements.

Do not disconnect any of the motor leads from the drive unless power is removed or the drive is disabled. Opening any one motor lead may destroy the drive.

- Use 16–20 AWG wire for speed adjust potentiometer wiring. Use 14–16 AWG wire for AC line (L1, L2) and motor (A1 and A2) wiring.

Shielding guidelines



Warning

Under no circumstances should power and logic leads be bundled together. Induced voltage can cause unpredictable behavior in any electronic device, including motor controls.

As a general rule, Leeson recommends shielding of all conductors.

If it is not practical to shield power conductors, Leeson recommends shielding all logic-level leads. If shielding logic leads is not practical, the user should twist all logic leads with themselves to minimize induced noise.

It may be necessary to earth ground the shielded cable. If noise is produced by devices other than the drive, ground the shield at the drive end. If noise is generated by a device on the drive, ground the shield at the end away from the drive. Do not ground both ends of the shield.

If the drive continues to pick up noise after grounding the shield, it may be necessary to add AC line filtering devices, or to mount the drive in a less noisy environment.

Logic wires from other input devices, such as motion controllers and PLL velocity controllers, must be separated from power lines in the same manner as the logic I/O on this drive.

Heat sinking

Model 174311 requires an additional heat sink when the continuous armature current is above 5 ADC. Use Leeson part number 174314. Use a thermally conductive heat sink compound between the drive chassis and heat sink surface for optimum heat transfer.

No additional heat sinking is required for Model M1740007.

Line fusing

The National Electric Code requires the installation of a circuit breaker or fuse on the incoming AC line voltage. When the AC line voltage is 115 VAC, fuse the hot leg of the AC line that connects to L1 and leave L2 unfused. When the AC line voltage is 230 VAC, fuse both L1 and L2. Use a circuit breaker or fuse that is rated approximately 150% of the maximum motor armature current. See Table 1 (page 14) for recommended line fuse sizes.

Table 1. Recommended Line Fuse Sizes

MOTOR HP	FUSE SIZE (AMPS)	
	@ 115 VAC INPUT	@ 230 VAC INPUT
1/4	5	3
1/3	8	3
1/2	8	5
3/4	10	8
1	15	8
1 1/2	—	10
2	—	15
3	—	30

Speed adjust potentiometer



Warning

Be sure that the potentiometer tabs do not make contact with the potentiometer enclosure. Grounding the input will cause damage to the drive.

On chassis drives, install the circular insulating disk between the panel and the 10K ohm speed adjust potentiometer. Mount the speed adjust potentiometer through a 0.38 in. (10 mm) hole with the hardware provided (Figure 8). Twist the speed adjust potentiometer wire to avoid picking up unwanted electrical noise. If potentiometer leads are longer than 18 in. (457 mm), use shielded cable.

All cased drives come with the speed adjust potentiometer installed.

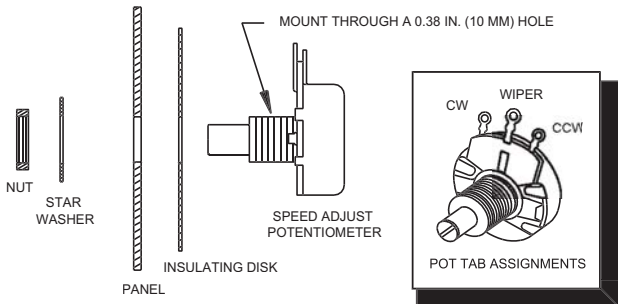

Figure 8. Speed Adjust Potentiometer

Connections



Warning

Do not connect this equipment with power applied.

Failure to heed this directive may result in fire or serious injury.

Leeson strongly recommends the installation of a master power switch in the voltage input line, as shown in Figure 9 (page 18). The switch contacts should be rated at a minimum of 200% of motor nameplate current and 250 volts.

Connect the power input leads, an external line fuse and a DC motor to TB501 on the drive's printed circuit board (PCB) as shown in Figure 9, page 18.

Motor

Leeson drives supply motor voltage from A1 and A2 terminals. It is assumed throughout this manual that, when A1 is positive with respect to A2, the motor will rotate clockwise (CW) while looking at the output shaft protruding from the front of the motor. If this is opposite of the desired rotation, simply reverse the wiring of A1 and A2 with each other.

Connect a DC motor to PCB terminals A1 and A2 as shown in Figure 9. Ensure that the motor voltage rating is consistent with the drive's output voltage.

Warning



The field output is for shunt wound motors only. Do not make any connections to F1 and F2 when using a permanent magnet motor.

See Table 2 for field output connections. Use 18 AWG wire to connect the field output to a shunt wound motor.

Table 2. Field Output Connections

Line Voltage (VAC)	Approximate Field Voltage (VDC)	Connect Motor Field To
115	50	F1 and L1
115	100	F1 and F2
230	100	F1 and L1
230	200	F1 and F2

Power input

Connect the AC line power leads to PCB terminals L1 and L2, or to a single-throw, double-pole master power switch (recommended). The switch should be rated at a minimum of 250 volts and 200% of motor current.

Line fuse

Wire an external line fuse between the stop switch (if installed) and the L1 terminal on the PCB. An additional line fuse should be installed on L2 if the input voltage is 230VAC. The line fuse(s) should be rated at 250 volts and 150 - 200% of maximum motor nameplate current. Refer to the line fuse chart on page 14 for fuse ratings.

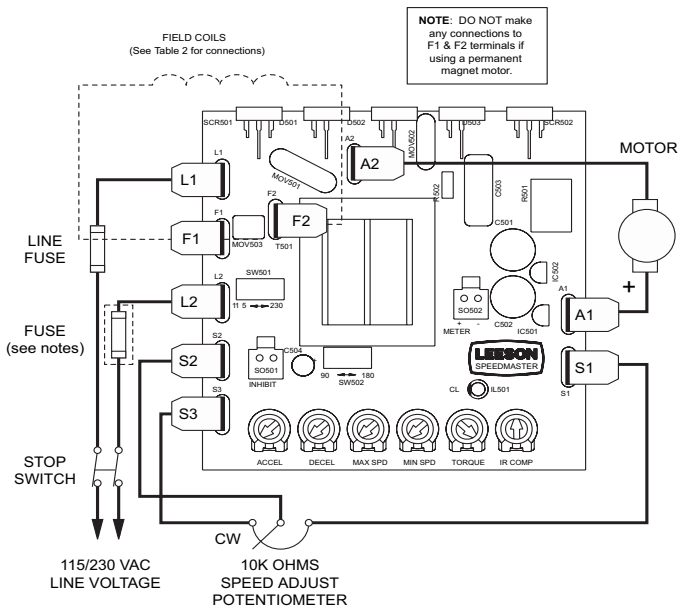

NOTE: DO NOT ADD LINE FUSE TO L2 UNLESS LINE VOLTAGE IS 230 VAC.

Figure 9. Chassis Drive Connections

Voltage follower

Instead of using a speed adjust potentiometer, the drive may be wired to follow a voltage signal that is isolated from earth ground (Figure 10). Connect the signal input (+) to S2. Connect the signal common (-) to S1. Make no connection to S3. A potentiometer can be used to scale the analog input voltage.

For 90 VDC motors, the voltage range is 0 - 1.4 VDC. For 180 VDC motors, the voltage range is 0 - 2.8 VDC.

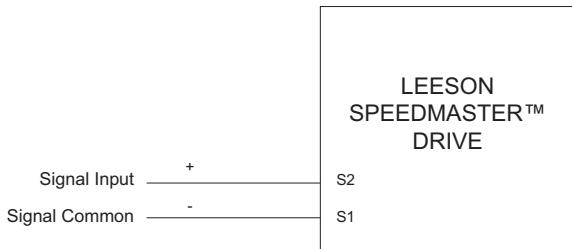

Figure 10. Voltage Follower Connections

Cased drive installation

Mounting (NEMA 1 enclosures)

NEMA 1 cased drives come with 0.88 inch (22 mm) conduit holes at the bottom of the case. The units may be vertically wall mounted or horizontally bench mounted using the three keyholes on the back of the case (see Figure 11). To mount the drive:

1. For access to the keyholes and the terminal strip, remove the two screws from the front of the case by turning them counterclockwise. Grasp the front cover and lift it straight out.
2. Install the mounting screws in the three keyholes.
3. Install conduit hardware through the conduit holes at the bottom of the case. Connect external wiring to the terminal block.
4. Reinstall the front cover. Avoid pinching any wires between the front cover and the case.
5. Replace the two screws to the front cover. Turn the screws clockwise to tighten.
6. Set the POWER switch to the OFF position before applying the AC line voltage.

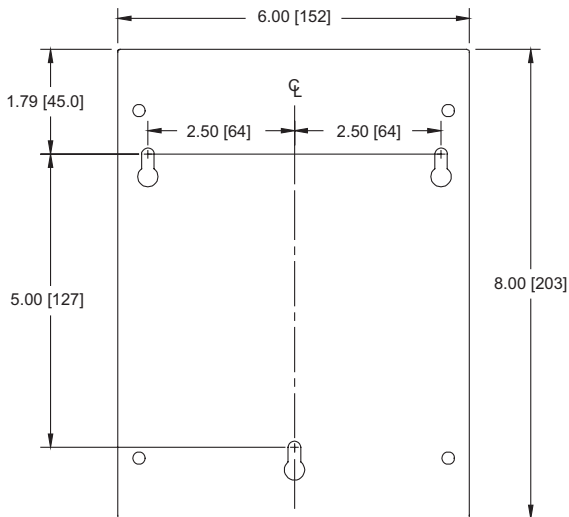

Figure 11. NEMA 1 Mounting Hole Locations

Mounting (NEMA 4 and NEMA 4/12 enclosures)

NEMA 4/12 cased drives (models 174100 and 174105) come with two 0.88 inch (22 mm) conduit knockout holes at the bottom of the case. Model 174709, a NEMA 4 cased drive, comes with three knockout holes at the bottom of the case. All NEMA 4 and NEMA 4/12 drives may be vertically wall mounted using the four 0.19 inch (5 mm) slotted holes on the attached heat sink. For motor loads less than 5 ADC, the drive may be bench mounted horizontally, or operated without mounting.

To mount the drive:

1. Install the mounting screws.
2. For access to the terminal strip, turn the slotted screw on the front cover counterclockwise until it is free from the case. The right side of the cover is hinged to the case. Pull the slotted screw to open the case.
3. Carefully remove the conduit knockouts by tapping them into the case and twisting them off with pliers.
4. Install conduit hardware through the 0.88 inch (22 mm) knockout holes. Connect external wiring to the terminal block.
5. Grasp the slotted screw and tilt the front cover back into place. Avoid pinching any wires between the front cover and the case.
6. Turn the slotted screw clockwise until tight to secure the front cover.
7. Set the POWER switch to the OFF position before applying the AC line voltage.

Heat sinking

Models 174307 and 174308 require an additional heat sink, Leeson part number 174316, when the continuous armature current is above 5 ADC. Use a thermally conductive heat sink compound between the back of the drive case and heat sink surface for optimum heat transfer.

All other cased drives do not require additional heat sinking to operate up their rated output current.

Line fusing

Line fuses are preinstalled on all cased drives. Models 174307, 174308, 174100, and 174105 have 15A line fuses; model 174709 has 30A line fuses; and models M1740005 and M1740006 have 3A line fuses. If the horsepower rating of the motor being used is less than the maximum horsepower rating of the drive, the line fuse may have to be replaced with a lower rated one. Refer to Table 1 on page 14 for recommended line fuse sizes.

Connections



Warning

Do not connect this equipment with power applied.

Failure to heed this directive may result in fire or serious injury.

For all Leeson cased controls except the 174709 series, connect the power input leads and a DC motor to the drive's terminal block as shown in Figure 12 (page 24). If you use a Leeson 174709 series cased control, connect the control as shown in Figure 13 (page 24).

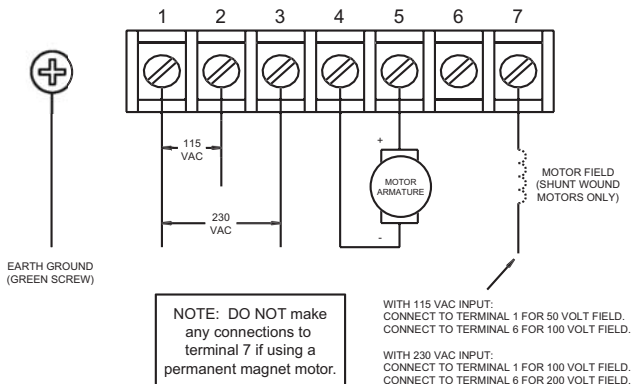

Figure 12. Cased Drive Connections

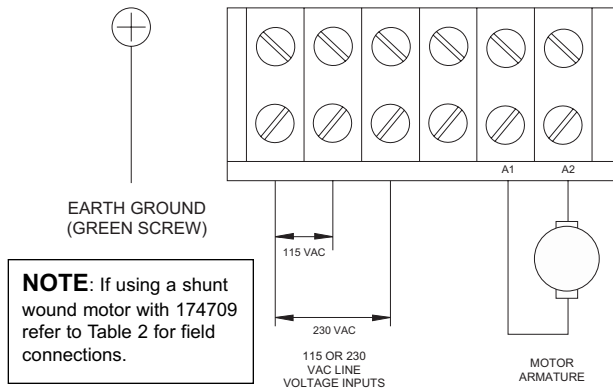

Figure 13. 174709 Connections

Operation



Warning

Change voltage switch settings only when the drive is disconnected from AC line voltage. Make sure both switches are set to their correct position. If the switches are improperly set to a lower voltage position, the motor will not run at full voltage. If the switches are improperly set to a higher voltage position, the motor will overspeed, which may cause motor damage.

Before applying power

- Set voltage switch SW501 to either 115 or 230 to match the AC line voltage. Set voltage switch SW502 to either 90 or 180 to match the maximum armature voltage (see Figure 14).
- Verify that no conductive material is present on the printed circuit board.
- If using a 90 VDC or 130 VDC motor with 230 VAC line voltage, derate the nameplate motor speed and torque by at least 30%.

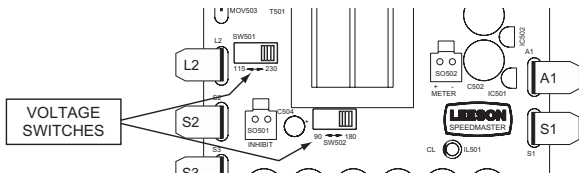

Figure 14. Voltage Switches

Startup

174311 and M1740007

1. Turn the speed adjust potentiometer full counterclockwise (CCW).
2. Apply AC line voltage.
3. Slowly advance the speed adjust potentiometer clockwise (CW). The motor slowly accelerates as the potentiometer is turned CW. Continue until the desired speed is reached.
4. Remove AC line voltage from the drive to coast the motor to a stop.

174100, 174307, 174709, and M1740005

1. Set the speed adjust potentiometer to "0" (full CCW).
2. Apply AC line voltage.
3. Set the POWER switch to the ON position.
4. Slowly advance the speed adjust potentiometer CW. The motor slowly accelerates as the potentiometer is turned CW. Continue until the desired speed is reached.
5. Set the POWER switch to the OFF position to coast the motor to a stop.

174308 and M1740006



Warning

Do not change the FORWARD/ REVERSE switch while the motor is running. The motor must come to a complete stop before reversing. Changing motor direction before allowing the motor to completely stop will cause excessively high current to flow in the armature circuit, and may damage the drive and/or motor.

1. Set the RUN/BRAKE switch to the BRAKE position.
2. Set the speed adjust potentiometer to "0" (full CCW).
3. Apply AC line voltage.
4. Set the POWER switch to the ON position.
5. Set the FORWARD/REVERSE switch to the desired direction of rotation.
6. Set the RUN/BRAKE switch to the RUN position.
7. Slowly advance the speed adjust potentiometer CW. The motor slowly accelerates as the potentiometer is turned CW. Continue until the desired speed is reached.
8. To brake the motor, set the RUN/BRAKE switch to the BRAKE position. To coast the motor to a stop, set the POWER switch to the OFF position.
9. To reverse direction:
 - a. Set the RUN/BRAKE switch to the BRAKE position.
 - b. Set the FORWARD/REVERSE switch to the desired direction of rotation.
 - c. Set the RUN/BRAKE switch to the RUN position.

174105



Warning

Do not change the FORWARD/ REVERSE switch while the motor is running. The motor must come to a complete stop before reversing. Changing motor direction before allowing the motor to completely stop will cause excessively high current to flow in the armature circuit, and may damage the drive and/or motor.

1. Set the FORWARD/BRAKE/REVERSE switch to the BRAKE position.
2. Set the speed adjust potentiometer to "0" (full CCW).
3. Apply AC line voltage.
4. Set the POWER switch to the ON position.
5. Set the FORWARD/BRAKE/REVERSE switch to the desired direction of rotation.
6. Slowly advance the speed adjust potentiometer CW. The motor slowly accelerates as the potentiometer is turned CW. Continue until the desired speed is reached.
7. To brake the motor, set the FORWARD/BRAKE/REVERSE switch to the BRAKE position. To coast the motor to a stop, set the POWER switch to the OFF position.
8. To reverse direction:
 - a. Set the FORWARD/BRAKE/REVERSE switch to the BRAKE position.
 - b. After the motor comes to a complete stop, set the FORWARD/BRAKE/REVERSE switch to the desired direction of rotation.

All drives

If the motor or drive does not perform as described, disconnect the AC line voltage immediately. Refer to ***Troubleshooting***, page 49, for further assistance.

Starting and Stopping Methods



Warning

Decelerating to minimum speed, dynamic braking, inhibit operation, or coasting to a stop (shorting S1 to S2) is recommended for frequent starts and stops. Do not use any of these methods for emergency stopping. They may not stop a drive that is malfunctioning. Removing AC line power (both L1 and L2) is the only acceptable method for emergency stopping.

Line starting and line stopping

Line stopping (removing AC line voltage) is recommended for infrequent stopping of a drive only. When AC line voltage is applied to the drive, the motor accelerates to the speed set by the speed adjust potentiometer. When AC line voltage is removed, the motor coasts to a stop.

Inhibit circuit

Maintaining a connection between the inhibit pins causes the motor to coast to minimum speed. Removing the connection between the inhibit pins allows the motor to accelerate to the speed set by the speed adjust potentiometer (Figure 15).

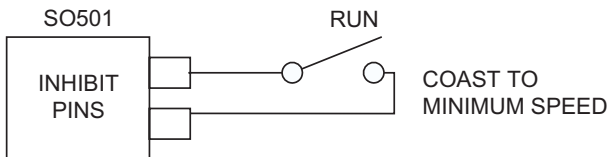

Figure 15. Inhibit Plug with Run/Coast to Minimum Speed Switch

Decelerating to minimum speed

The circuit shown in Figure 16 may be used to decelerate a motor to a minimum speed. Closing the switch between S1 and S2 decelerates the motor from set speed to a minimum speed determined by the MIN SPD trimpot setting. If the MIN SPD trimpot is set full CCW, the motor decelerates to zero speed when the switch between S1 and S2 is closed. The DECEL trimpot setting determines the rate at which the drive decelerates. By opening the switch, the motor accelerates to set speed at a rate determined by the ACCEL trimpot setting.

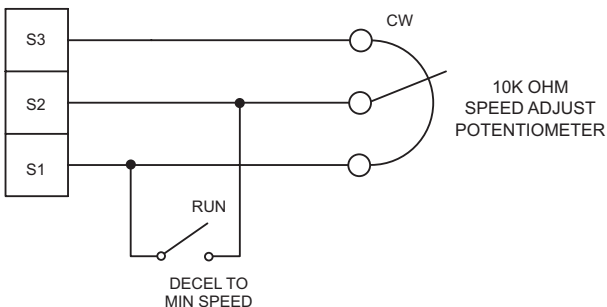

Figure 16. Run/Decelerate to Minimum Speed Switch

Dynamic braking



Warning

Wait for the motor to completely stop before switching it back to RUN. This will prevent high armature currents from damaging the motor or drive.

Dynamic braking may be used to rapidly stop a motor (Figure 17). For the RUN/BRAKE switch, use a double pole, double throw switch rated for at least the maximum DC armature voltage and maximum braking current.

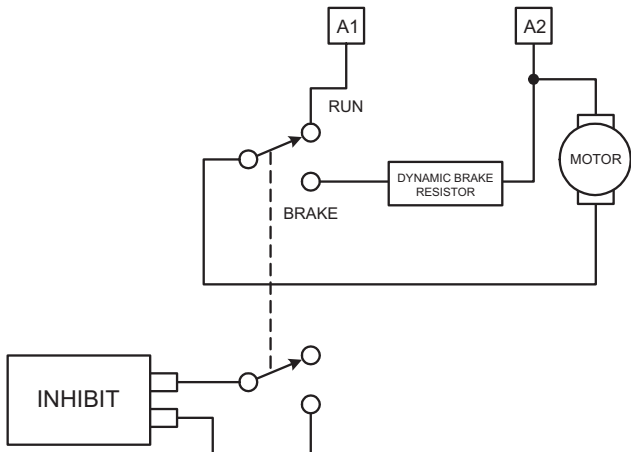

Figure 17. Dynamic Brake Connection

Sizing the dynamic brake resistor

Size the dynamic brake resistor according to the motor current rating (Table 3). The dynamic brake resistance listed in the table is the smallest recommended resistance allowed to prevent possible demagnetization of the motor. The motor stops less rapidly with higher brake resistor values.

Table 3. Recommended Dynamic Brake Resistor Sizes

Motor Armature Current Rating Wattage	Minimum Dynamic Brake Resistor Value	Minimum Dynamic Brake Resistor
Less than 2 ADC	1 ohm	1W
2–3 ADC	5 ohm	5W
3–5 ADC	10 ohm	10W
5–10 ADC	20 ohm	20W
10–17 ADC	40 ohm	50W

For motors rated 1/17 horsepower and lower, a brake resistor is not necessary since the armature resistance is high enough to stop the motor without demagnetization. Replace the dynamic brake with 12 gauge wire.

NOTE: Models 174105, 174308 and M1740006 are factory-equipped with dynamic braking.

Calibration



Warning

Dangerous voltages exist on the drive when it is powered. When possible, disconnect the voltage input from the drive before adjusting the trimpots. If the trimpots must be adjusted with power applied, use insulated tools and the appropriate personal protection equipment. **BE ALERT.** High voltages can cause serious or fatal injury.

Each drive is factory calibrated to its maximum current rating. Readjust the calibration trimpot settings to accommodate lower current rated motors.

All adjustments increase with CW rotation, and decrease with CCW rotation. Use a non-metallic screwdriver for calibration. Each trimpot is identified on the printed circuit board. Refer to Figures 18 and 19 (pages 41-42) for typical TORQUE LIMIT and IR COMP settings.

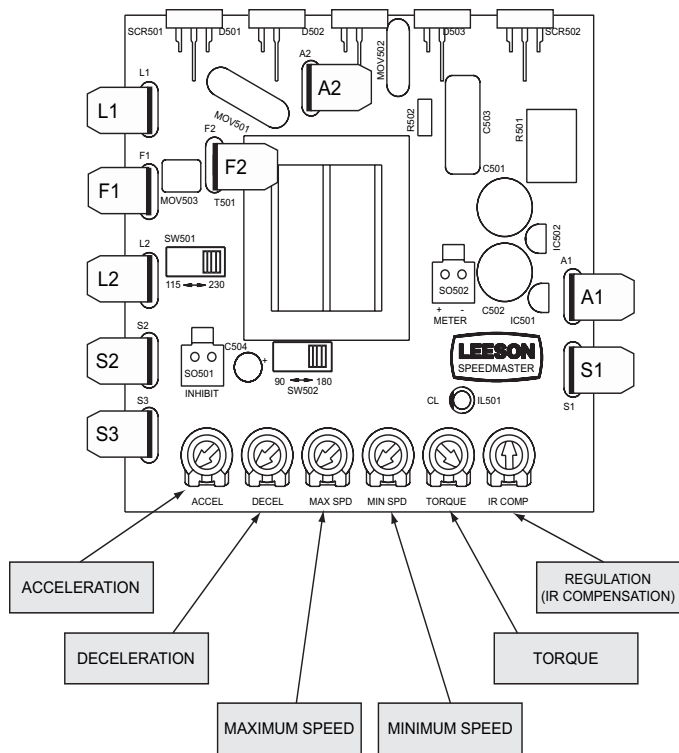

Figure 18. Calibration Trimpot Layout

Calibration procedure

Calibrate the drive using the following procedure:

1. Set the MIN SPD, MAX SPD, ACCEL and DECEL trimpots to zero (full CCW).
2. Set the TORQUE trimpot to maximum (full CW).
3. Set the IR COMP trimpot to midrange (approximate 12 o'clock position).
4. Set the signal input (analog voltage signal or speed adjust potentiometer) to zero.
5. Apply power to the drive.
6. Calibrate the trimpots as follows:

MINIMUM SPEED (MIN SPD)

The MIN SPD setting determines the motor speed when the speed adjust potentiometer is turned full CCW. It is factory set to zero speed.

To calibrate, turn the speed adjust potentiometer full CCW. Adjust the MIN SPD trimpot until the motor has stopped, or is running at the desired minimum speed.

MAXIMUM SPEED (MAX SPD)

The MAX SPD setting determines the motor speed when the speed adjust potentiometer is turned full CW. It is factory set for maximum rated speed.

To calibrate, set the MAX SPD trimpot full CCW. Turn the speed adjust potentiometer full CW. Adjust the MAX SPD trimpot until the desired maximum motor speed is reached.

Note: Check the MIN SPD and MAX SPD adjustments after recalibrating to verify that the motor runs at the desired minimum and maximum speed.

REGULATION (IR COMP)

The IR COMP setting determines the degree to which motor speed is held constant as the motor load changes. It is factory set for optimum motor regulation.

Recalibrate the IR COMP setting when using a lower horsepower motor. Refer to the recommended IR COMP settings on page 41 and 42, or recalibrate using the following procedure:

If the motor does not maintain set speed as the load changes, gradually rotate the IR COMP trimpot CW. If the motor oscillates (overcompensation), the IR COMP trimpot may be set too high. Turn the IR COMP trimpot CCW to stabilize the drive.

TORQUE LIMIT (TORQUE)



Warning

Although TORQUE is set to 120% of drive nameplate current rating, continuous operation beyond that rating may damage the motor. If you intend to operate beyond the rating, contact your Leeson representative for assistance.

The TORQUE setting determines the maximum torque for accelerating and driving the motor. TORQUE is factory set at 120% of maximum drive current. You must recalibrate the TORQUE setting if using a lower current rated motor. See Figure 19 (page 41) and Figure 20 (page 42) for typical TORQUE and IR COMP settings.

1. With no power applied to the drive, connect a DC ammeter in series with the motor armature.
2. Set the TORQUE trimpot to full CCW.
3. Carefully lock the motor armature. Ensure that the motor is firmly mounted.
4. Apply line power. The motor should be stopped.
5. Set the speed potentiometer or reference signal to maximum speed. The motor should remain stopped.
6. Slowly rotate the TORQUE trimpot clockwise (CW) until the ammeter reads 120% of maximum motor armature current.
7. Set the speed adjust potentiometer or reference signal to zero speed.

8. Remove power from the drive.
9. Remove the lock from the motor shaft.
10. Remove the ammeter in series with the motor armature.

ACCELERATION (ACCEL)

The ACCEL setting determines the time the motor takes to ramp to a higher speed. See **Specifications** on page 1 for approximate acceleration times. The ACCEL setting is factory set to its minimum value (full CCW).

Turn the ACCEL trimpot CW to increase the acceleration time, and CCW to decrease the acceleration time.

DECELERATION (DECEL)

The DECEL setting determines the time the motor takes to ramp to a lower speed. See **Specifications** on page 1 for approximate deceleration times. The DECEL setting is factory set to its minimum value (full CCW).

Turn the DECEL trimpot CW to increase the deceleration time, and CCW to decrease the deceleration time.

Calibration procedure conclusion

This concludes the calibration procedure. The control should now be calibrated for optimum operation.

Models M1740005, M1740006, and M1740007



TORQUE



IR COMP

1/8 HP
90 VDC
1800 RPM
1.3 AMPS



TORQUE



IR COMP

1/4 HP
180 VDC
1800 RPM
1.4 AMPS



TORQUE



IR COMP

1/15 HP
90 VDC
1800 RPM
0.77 AMPS



TORQUE



IR COMP

1/8 HP
180 VDC
1800 RPM
0.67 AMPS

Models 174100, 174105, 174307, 174308, and 174311



TORQUE



IR COMP

1 HP
90 VDC
1750 RPM
10 AMPS



TORQUE



IR COMP

2 HP
180 VDC
1750 RPM
9.2 AMPS



TORQUE



IR COMP

3/4 HP
90 VDC
1750 RPM
7.6 AMPS



TORQUE



IR COMP

1 1/2 HP
180 VDC
1750 RPM
7.0 AMPS



TORQUE



IR COMP

1/2 HP
90 VDC
1750 RPM
5.0 AMPS



TORQUE



IR COMP

1 HP
180 VDC
1750 RPM
5.0 AMPS



TORQUE



IR COMP

1/3 HP
90 VDC
1750 RPM
3.5 AMPS



TORQUE



IR COMP

3/4 HP
180 VDC
1750 RPM
3.8 AMPS



TORQUE



IR COMP

1/4 HP
90 VDC
1750 RPM
2.7 AMPS



TORQUE



IR COMP

1/2 HP
180 VDC
1750 RPM
1.3 AMPS

Figure 19. Recommended TORQUE and IR COMP Settings

Model 174109



**Figure 20. Recommended TORQUE
and IR COMP Settings for 174109 Series Controls**

Application Notes

Multiple fixed speeds

Replace the speed adjust potentiometer with series resistors with a total series resistance of 10K ohms (Figure 21). Add a single pole, multi-position switch with the correct number of positions for the desired number of fixed speeds.

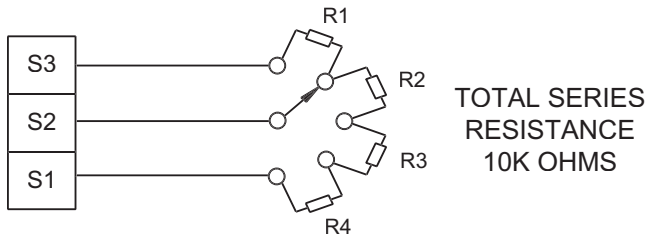

Figure 21. Multiple Fixed Speeds

Adjustable speeds using potentiometers in series

Replace the speed adjust potentiometer with a single pole, multi-position switch, and two or more potentiometers in series, with a total series resistance of 10K ohms. Figure 22 shows a connection for fixed high and low speed adjust potentiometers.

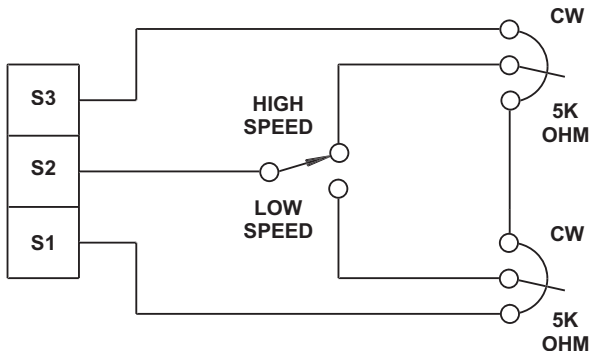

Figure 22. Adjustable Fixed Speeds Using Potentiometers in Series

Independent adjustable speeds

Replace the speed adjust potentiometer with a single pole, multi-position switch, and two or more potentiometers in parallel, with a total parallel resistance of 10K ohms. Figure 23 shows the connection of two independent speed adjust potentiometers that can be mounted at two separate operating stations.

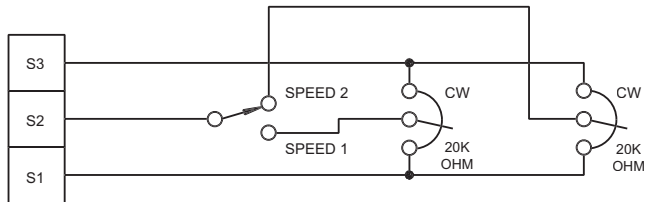

Figure 23. Independent Adjustable Speeds

RUN/JOG switch

Using a RUN/JOG switch is recommended in applications where quick stopping is not needed and frequent jogging is required. Use a single pole, two position switch for the RUN/JOG switch, and a single pole, normally closed, momentary operated pushbutton for the JOG pushbutton.

RUN/JOG option #1

In the first wiring option, connect the RUN/JOG switch and JOG pushbutton to the inhibit plug as shown in Figure 24. The motor coasts to a stop when the RUN/JOG switch is set to JOG. Press the JOG pushbutton to jog the motor. Return the RUN/JOG switch to RUN for normal operation.

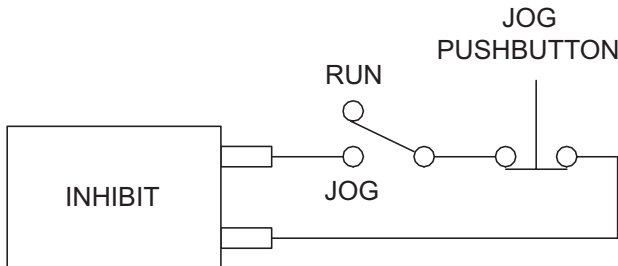

Figure 24. RUN/JOG Switch Option #1

RUN/JOG option #2

In the second wiring option, connect the RUN/JOG switch and the JOG pushbutton as shown in the Figure 25. When the RUN/JOG switch is set to JOG, the motor decelerates to minimum speed (minimum speed is determined by the MIN SPD trimpot setting). Press the JOG pushbutton to jog the motor. Return the RUN/JOG switch to RUN for normal operation.

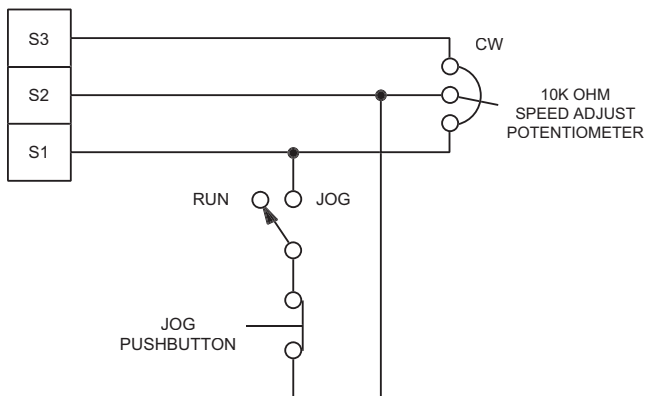

Figure 25. RUN/JOG Switch Option #2

Reversing

A dynamic brake may be used when reversing the motor direction (Figure 26). Use a three pole, three position switch rated for at least the maximum DC armature voltage and maximum braking current. When in the brake position, wait for the motor to stop completely before switching it to either the forward or reverse direction. See the *Dynamic braking* section, page 32, for sizing the dynamic brake resistor.

Note: Model 174709 is equipped with this reversing feature.

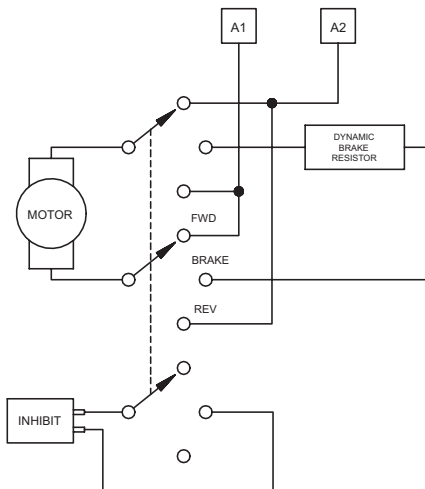

Figure 26. Reversing Circuit Connection

Troubleshooting



Warning

Dangerous voltages exist on the drive when it is powered. When possible, disconnect the drive while troubleshooting. High voltages can cause serious or fatal injury.

Before troubleshooting

Perform the following steps before starting any procedure in this section:

- Disconnect AC line voltage from the drive.
- Check the drive closely for damaged components.
- Check that no conductive or other foreign material has become lodged on the printed circuit board.
- Verify that every connection is correct and in good condition.
- Verify that there are no short circuits or grounded connections.
- Check that the voltage switch settings match the AC line and maximum armature output voltages.
- Check that the drive's rated armature outputs are consistent with the motor ratings.

Current limit LED (174011 and M1740007)

174011 and M1740007 series drives are equipped with a red, PCB-mounted current limit LED. The red current limit LED turns on whenever the drive reaches current limit and turns off whenever the drive is not in current limit (normal operation).

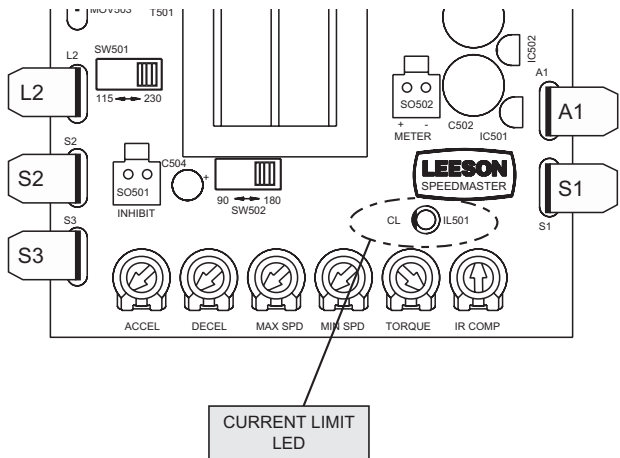

Figure 27. Current Limit LED

Symptom	Possible Causes	Suggested Solutions
Fuse blows or circuit breaker trips	<ol style="list-style-type: none">1. Line fuses or circuit breakers are the wrong size.2. Motor cable or armature is shorted to ground.3. Nuisance tripping caused by a combination of ambient conditions and high-current spikes.	<ol style="list-style-type: none">1. Check that line fuses or circuit breakers are the proper size.2. Check motor cable and armature for shorts.3. Add a blower to cool the drive components; decrease TORQUE settings, or resize motor and drive for actual load demand, or check for incorrectly aligned mechanical components or “jams”. See page 39 for information on adjusting the TORQUE trimpot.
Line fuse does not blow or circuit breaker does not trip, but the motor does not run	<ol style="list-style-type: none">1. Reference signal or speed adjust pot is set to zero speed.2. Reference signal or speed adjust potentiometer connections are open.	<ol style="list-style-type: none">1. Increase reference signal or speed adjust potentiometer setting.2. Check that the reference signal or speed adjust potentiometer connections are not open.

Symptom	Possible Causes	Suggested Solutions
Line fuse does not blow or circuit breaker does not trip, but the motor does not run (cont.)	3. Drive is in current limit. 4. Drive is not receiving AC line voltage. 5. Motor is not connected.	3. Verify that the motor is not jammed. Increase TORQUE setting (page 39). 4. Apply AC line voltage to L1 and L2. 5. Connect motor to A1 and A2.
Motor runs too fast at maximum speed setting	1. MIN SPD and MAX SPD settings are too high.	1. Recalibrate MIN SPD (page 37) and MAX SPD (page 38).
Motor runs too slow or too fast	MIN SPD and MAX SPD are not calibrated.	1. Recalibrate MIN SPD (page 37) and MAX SPD (page 38).
Motor will not reach the desired speed.	1. MAX SPD setting is too low. 2. IR COMP setting is too low. 3. Motor is overloaded.	1. Increase MAX SPD setting (page 38). 2. Increase IR COMP setting (page 38). 3. Check motor load. Resize the motor or drive if necessary.

Symptom	Possible Causes	Suggested Solutions
Motor pulsates or surges under load	<ol style="list-style-type: none">1. IR COMP is set too high.2. Control is in current limit mode.	<ol style="list-style-type: none">1. Adjust the IR COMP setting slightly CCW until the motor speed stabilizes (page 38).2. Check that motor is of sufficient horsepower and amperage.
On non-reversing drives, motor runs in the opposite direction	<ol style="list-style-type: none">1. Motor armature leads are reversed.	<ol style="list-style-type: none">1. Reverse connections to the motor armature.
Motor will not stop when the speed adjust potentiometer or reference signal is set to zero speed.	<ol style="list-style-type: none">1. MIN SPD trimpot is not adjusted properly.	<ol style="list-style-type: none">1. Slowly rotate the MIN SPD trimpot until the motor stops.

DISCLAIMER

The information and technical data in this manual are subject to change without notice. LEESON Electric Corporation makes no warranty of any kind with regard to this material, including, but not limited to, the implied warranties of merchantability and fitness for a particular purpose. LEESON Electric Corporation assumes no responsibility for any errors that may appear in this manual and makes no commitment to update or to keep current the information in this manual.



ELECTRIC MOTORS, GEARMOTORS AND DRIVES

LEESON ELECTRIC CORPORATION

GRAFTON, WI 53024-0241 U.S.A. TELEPHONE (262) 377-8810 FAX (262) 377-9025

PRINTED IN U.S.A.
DOCUMENT NO. 250-0218, Revision 6